

UNIVERSITY OF DAIYLA

COLLEGE OF ENGINEERING

CHEMICAL ENGINEERING DEPARTMENT

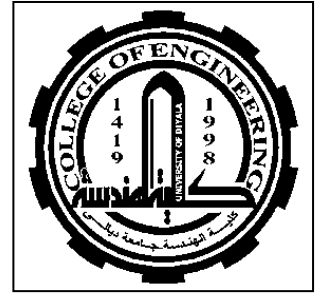

CORROSION

For
Chemical Engineering Students

by
Assist. Prof. Dr. **Anees A. Khadom**

Ph.D, Ms.C and Bs.C. Chemical Engineering

Chapter 1

Introduction

DEFINITION OF CORROSION

Corrosion is the destructive attack of a metal by chemical or electrochemical reaction with its environment. Deterioration by physical causes is not called corrosion, but is described as erosion, galling, or wear. In some instances, chemical attack accompanies physical deterioration, as described by the following terms: corrosion – erosion, corrosive wear, or fretting corrosion. Nonmetals are not included in this definition of corrosion. Plastics may swell or crack, wood may split or decay, granite may erode, and Portland cement may leach away, but the term corrosion, in this book, is restricted to chemical attack of metals. “*Rusting*” applies to the corrosion of iron or iron - base alloys with formation of corrosion products consisting largely of hydrous ferric oxides. Nonferrous metals, therefore, corrode, but do not rust. Corrosion is a return of material to its origin.

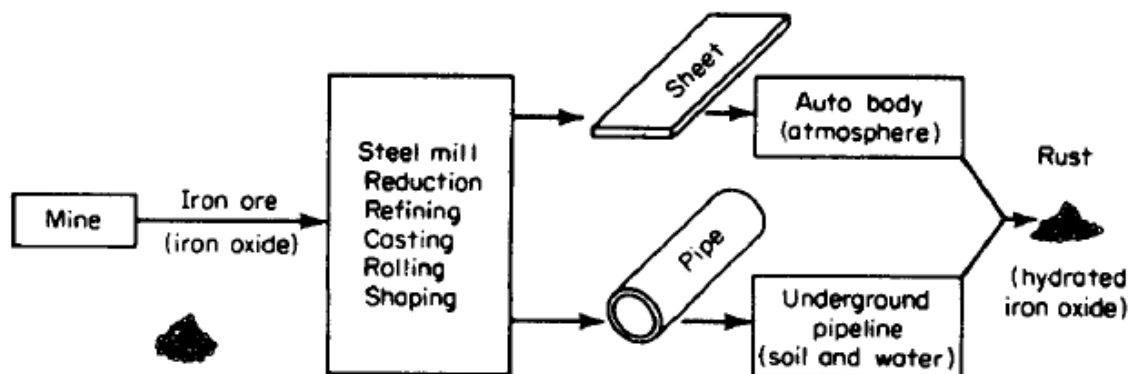

- **Four** required components in an electrochemical corrosion cell: 1) An anode; 2) A cathode; 3) A conducting environment for ionic movement (electrolyte); 4) An electrical connection between the anode and cathode for the flow of electron current.
- **If any of the above components is missing** or disabled, the electrochemical corrosion process will be stopped.

IMPORTANCE OF CORROSION

The three main reasons for the importance of corrosion are:

1. Economics
2. Safety.
3. Conservation.

THE DRY -CELL ANALOGY AND FARADAY 'S LAW

Corrosion processes are most often electrochemical. In aqueous media, the corrosion reactions are similar to those that occur in a flashlight cell consisting of a center carbon electrode and a zinc cup electrode separated by an electrolyte consisting essentially of NH_4Cl solution (Fig. 2.1).

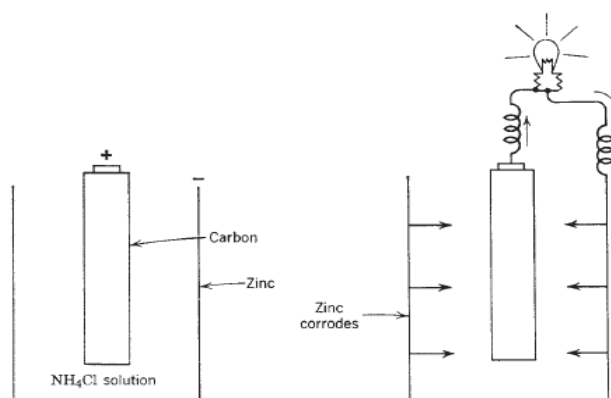

Figure 2.1. Dry cell.

The greater the flow of electricity through the cell, the greater the amount of zinc that corrodes. The relationship is quantitative, as *Michael Faraday* showed in the early nineteenth century. This is the relationship now known as *Faraday's law*:

$$\text{Weight of metal reacting} = k I t \quad (2.1)$$

Where I is the current in amperes (A), t is in seconds (s), and k is a constant called the *electrochemical equivalent*. The value of k for zinc is 3.39×10^{-4} g/C (gram per coulomb), the coulomb being defined as the amount of electricity represented by 1 A flowing for 1 s. Any metal surface, similar to the situation for zinc, is a composite of electrodes electrically short - circuited through the body of the metal itself (Fig. 2.2). So long as the metal remains dry, local - action current and corrosion are not observed. But on exposure of the metal to water or aqueous solutions,

local - action cells are able to function and are accompanied by chemical conversion of the metal to corrosion products.

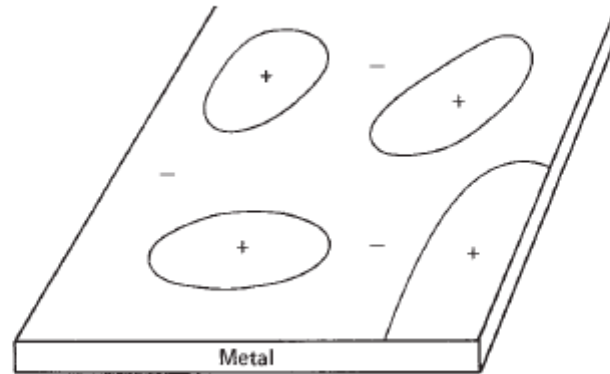
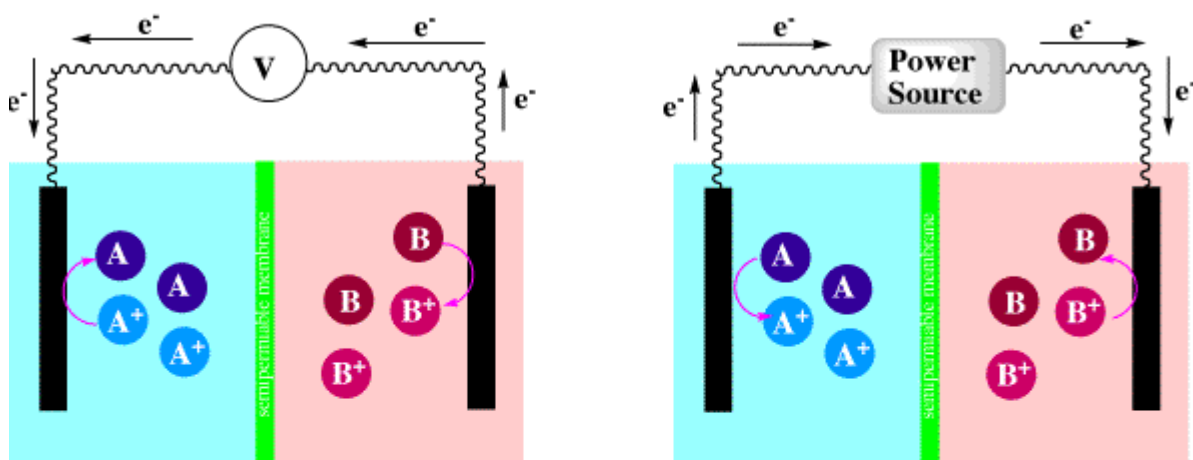

Figure 2.2. Metal surface enlarged, showing schematic arrangement of local-action cells.

GALVANIC AND ELECTROLYTIC CELLS

A *galvanic cell* convert chemical energy to electrical energy.

A *electrolytic cell* convert electrical energy to chemical energy.



Galvanic Cell



$$E^0 = 0.10 \text{ V}$$

Electrolytic Cell

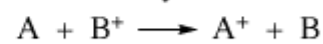

$$E^0 = -0.10 \text{ V}$$

	anode	cathode
galvanic cell	-	+
electrolytic cell	+	-

DEFINITION OF ANODE AND CATHODE

A combination of two electrical conductors (electrodes) immersed in an electrolyte is called a galvanic cell in honor of *Luigi Galvani*, a physician in Bologna, Italy, who published his studies of electrochemical action in 1791. A galvanic cell converts chemical energy into electrical energy. On short - circuiting such a cell (attaching a low - resistance wire to connect the two electrodes), positive current flows through the metallic path from positive electrode to negative electrode. The electrode at which chemical reduction occurs (or + current enters the electrode from the electrolyte) is called the *cathode* . Examples of cathodic reactions are

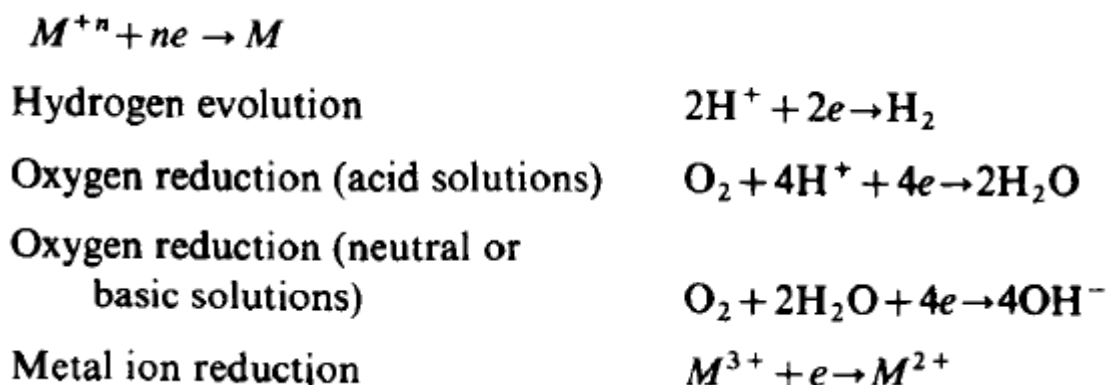

All of which represent reduction in the chemical sense. The electrode at which chemical oxidation occurs (or + electricity leaves the electrode and enters the electrolyte) is called the *anode*. Examples of anodic reactions are

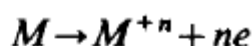

A few examples are:

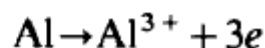
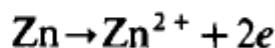

These equations represent oxidation in the chemical sense. Corrosion of metals usually occurs at the anode. In galvanic cells, the cathode is the positive pole, whereas the anode is the negative pole. *Cations* are ions that migrate toward the cathode when electricity flows through the cell (e.g., H^{+} , Fe^{2+}) and are always positively charged whether current is drawn from or supplied

to the cell. Similarly, anions are always negatively charged. Example of anodic – cathodic reaction is the corrosion of zinc in acid solution:

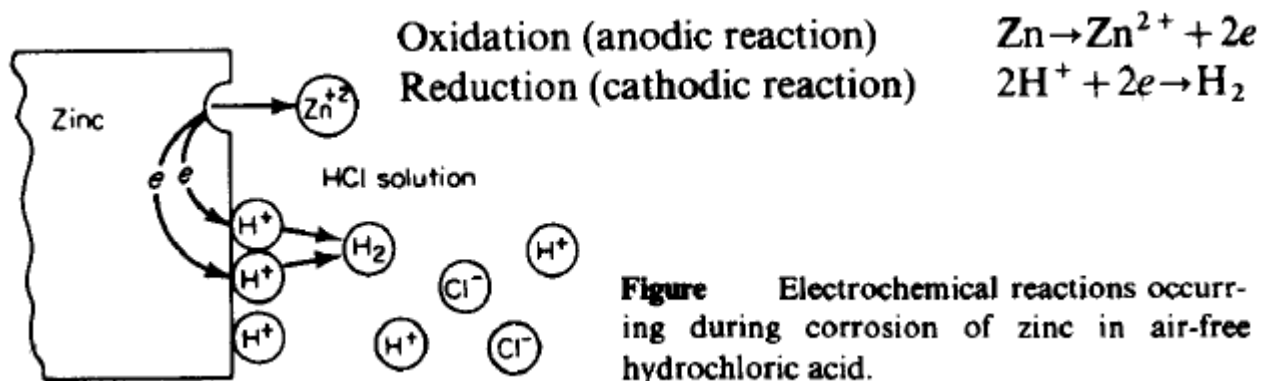

TYPES OF CELLS

There are three main types of cells that take part in corrosion reactions.

1. **Dissimilar Electrode Cells.** Examples of dissimilar electrode cells include: the dry cell, a metal containing electrically conducting impurities on the surface as a separate phase, a copper pipe connected to an iron pipe, and a bronze propeller in contact with the steel hull of a ship. Dissimilar electrode cells also include cold - worked metal in contact with the same metal annealed, grain – boundary metal in contact with grains, and a single metal crystal of definite orientation in contact with another crystal of different orientation.
2. **Concentration Cells.** These are cells with two identical electrodes, each in contact with a solution of different composition. There are two kinds of concentration cells.
 - a. The first is called a *salt concentration cell*. For example, if one copper electrode is exposed to a concentrated copper sulfate solution, and another to a dilute copper sulfate solution (Fig. 2.3), on short - circuiting the electrodes, copper dissolves (i.e., $Cu \rightarrow Cu^{2+} + 2e^-$) from the electrode in contact with the dilute solution (anode) and plates out (i.e., $Cu^{2+} + 2e^- \rightarrow Cu$) on the other electrode (cathode). These reactions tend to bring the two solutions to the same concentration.
 - b. The second kind of concentration cell, which in practice is the more important, is called a *differential aeration cell*. This may include two iron electrodes in dilute sodium

chloride solution, the electrolyte around one electrode being thoroughly aerated (cathode), and the other deaerated (anode) by, for example, bubbling nitrogen through the solution. The difference in oxygen concentration produces a potential difference and causes current to flow (Fig. 2.4).

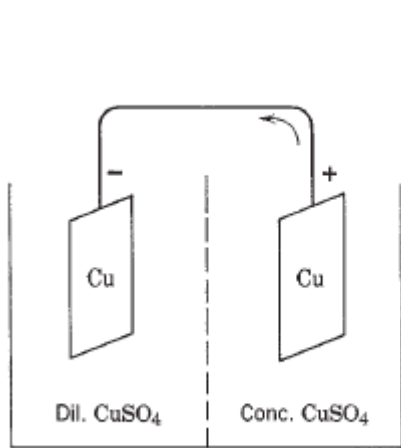

Figure 2.3. Salt concentration cell.

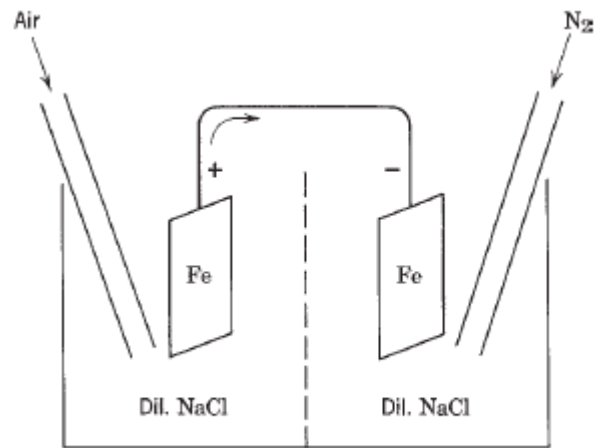

Figure 2.4. Differential aeration cell.

Differential aeration cells can also cause pitting damage under rust (Fig. 2.5) and at the water line — that is, at the water – air interface (Fig. 2.6). The amount of oxygen reaching the metal that is covered by rust or other insoluble reaction products is less than the amount that contacts other portions where the permeable coating is thinner or nonexistent.

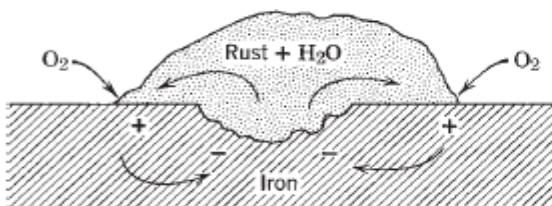

Figure 2.5. Differential aeration cell formed by rust on iron.

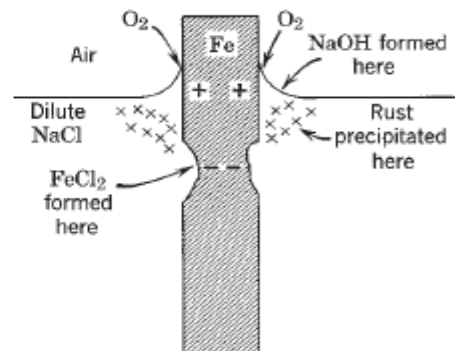

Figure 2.6. Water-line corrosion, showing differential aeration cell.

3. *Differential Temperature Cells*. Components of these cells are electrodes of the same metal, each of which is at a different temperature, immersed in an electrolyte of the same initial composition. Less is known about the practical importance and fundamental theory of differential temperature cells than about the cells previously described. These cells are found in heat exchangers, boilers, immersion heaters, and similar equipment.

CORROSION RATE EXPRESSION

Corrosion can be expressed in different ways and different units.

1. Mils per year (mpy)

$$\text{mpy} = \frac{534W}{DAT}$$

where W = weight loss, mg
 D = density of specimen, g/cm³
 A = area of specimen, sq. in.
 T = exposure time, hr

2. Gram per square meter per day (gmd)

$$\text{gmd} = \frac{g}{m^2 \cdot \text{day}} = \frac{W}{A \cdot T}$$

Multiply gmd by 0.365/density (g/cm³) to obtain mm/y.

3. Milligrams per square decimeter per day (mdd).
4. Millimeters per year (mm/y). (mm/y) × 2.74 × density (g/cm³) = gmd.
5. Inches per year (ipy). Multiply inches penetration per year (ipy) by 696 × density to obtain milligrams per square decimeter per day (mdd). Multiply mdd by 0.00144/density to obtain ipy.
6. Current density (amperes per square area) equivalent to a corrosion rate. 1 gmd = 1.117n / M amperes per square meter. $1 \text{ gmd} = \frac{1.117 n}{M} \left(\frac{A}{m^2} \right)$. where M is the gram atomic weight and n is number of electron.

For example, if the metal is steel or iron, $n=2$, $M=55.85$, density=7.88 g/cm³.

$$1 \text{ gmd} = \frac{1.117 \times 2}{55.85} = 0.04 \frac{A}{m^2} = 4 \frac{\mu A}{cm^2}$$

Corrosion rate can be used in predicting the severity of damage, for example:

i_{corr} ($\mu\text{A}/\text{cm}^2$)	Severity of Damage
<0.5	no corrosion damage expected
0.5-2.7	corrosion damage possible in 10 to 15 years
2.7-27	corrosion damage expected in 2 to 10 years
>27	corrosion damage expected in 2 years or less

Or another example for corrosion of *steel in concrete*:

i_{corr} ($\mu\text{A}/\text{cm}^2$)	(corrosion state)	i_{corr} ($\mu\text{A}/\text{cm}^2$)	(expected damage)
< 0.1	Passive	< 0.2	No damage expected
0.1 – 0.5	Low corrosion	0.2 – 1.1	Damage expected in 10-15 years
0.5 – 1.0	Moderate	1.1 – 11	Damage expected in 2-10 years
> 1.0	High corrosion	> 11	Damage expected in < years

TYPES OF CORROSION DAMAGE

1. **General Corrosion, or Uniform Attack**, Uniform or general corrosion, which is the simplest form of corrosion, is an even rate of metal loss over the exposed surface. It is generally thought of as metal loss due to chemical attack or dissolution of the metallic component into metallic ions. For handling chemical media whenever attack is uniform, metals are classified into three groups according to their corrosion rates and intended application. These classifications are as follows:
 - a. < 0.15 mm/y (< 0.005 ipy) — Metals in this category have good corrosion resistance to the extent that they are suitable for critical parts, for example, valve seats, pump shafts and impellers, springs.
 - b. 0.15 to 1.5 mm/y (0.005 to 0.05 ipy) — Metals in this group are satisfactory if a higher rate of corrosion can be tolerated, for example, for tanks, piping, valve bodies, and bolt heads.

- c. $> 1.5 \text{ mm/y}$ ($> 0.05 \text{ ipy}$) — Usually not satisfactory.
2. **Pitting.** This is a localized type of attack, with the rate of corrosion being greater at some areas than at others. Depth of pitting is sometimes expressed by the *pitting factor*, the ratio of deepest metal penetration to average metal penetration as determined by the weight loss of the specimen. A pitting factor of unity represents uniform attack.

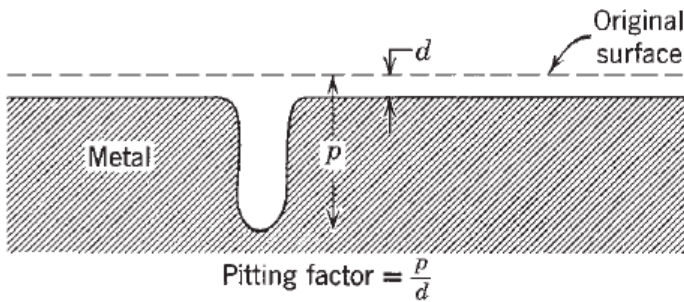
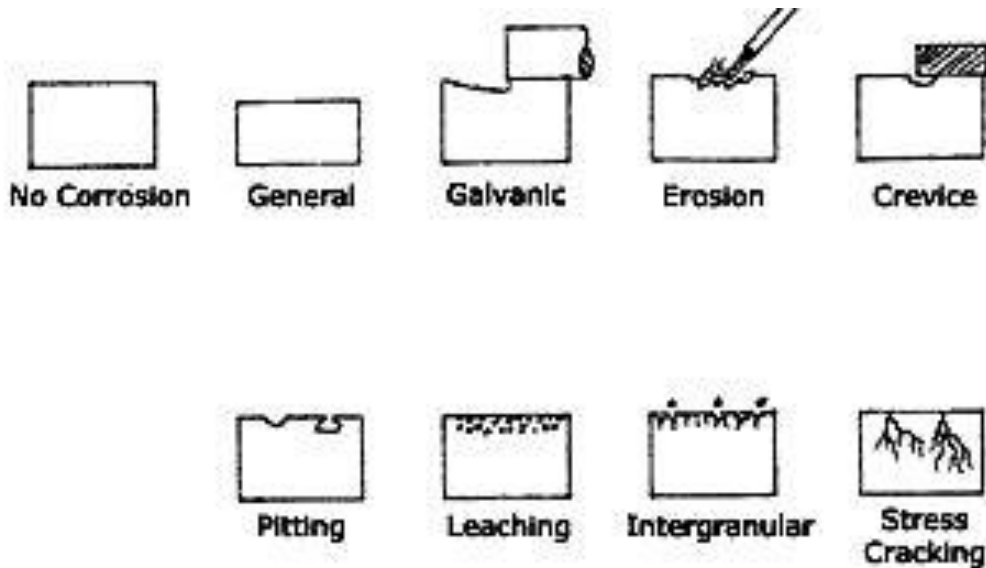

Figure Sketch of deepest pit in relation to average metal penetration and the pitting factor.

3. **Dealloying and Dezincification.** Dealloying is the selective removal of an element from an alloy by corrosion. One form of dealloying, dezincification, is a type of attack occurring with zinc alloys (e.g., yellow brass) in which zinc corrodes preferentially, leaving a porous residue of copper and corrosion products.
4. **Intergranular Corrosion.** This is a localized type of attack at the grain boundaries of a metal, resulting in loss of strength and ductility. Grain – boundary material of limited area, acting as anode, is in contact with large areas of grain acting as cathode.
5. **Galvanic Corrosion,** Dissimilar metals are physically joined in the presence of an electrolyte. The more anodic metal corrodes.
6. **Stress Corrosion Cracking, SCC,** A structure that has SCC sensitivity, if subjected to stresses and then exposed to a corrosive environment, may initiate cracks and crack growth well below the yield strength of the metal. Consequently, no corrosion products are visible, making it difficult to detect or prevent; fine cracks can penetrate deeply into the part.
7. **Erosion-corrosion,** Combined chemical attack and mechanical wear (e.g., pipe elbows).

8. **Crevice corrosion** refers to corrosion occurring in confined spaces to which the access of the working fluid from the environment is limited. These spaces are generally called crevices. Examples of crevices are gaps and contact areas between parts, under gaskets or seals.



PROBLEMS

1. Derive the general relation between mm/y and gmd.
2. Magnesium corrodes in seawater at a rate of 1.45 gmd. What is the rate in mm/y? If this corrosion rates applies to lead, what is the corresponding rate in mm/y?
3. Laboratory corrosion tests on three alloys in an industrial waste solution show the following results:

Material	Density of Material (g/cm ²)	Weight Loss (gmd)	Pitting Factor
A	2.7	40	1
B	9.0	62	2
C	7.8	5.6	9.2

Calculate maximum penetration in millimeters for each material at the end of one year.

Chapter 2

THERMODYNAMIC OF CORROSION REACTION AND ELECTRODE POTENTIAL

GIBBS FREE ENERGY

The change in Gibbs free energy associated with a chemical reaction is a useful indicator of whether the reaction will proceed spontaneously. A negative ΔG associated with a reaction indicates that it can happen spontaneously. For non-standard conditions one can make use of the expression for ΔG in terms of the other thermodynamic potentials:

$$\Delta G = \Delta H - T\Delta S$$

The tendency for any chemical reaction to go, including the reaction of a metal with its environment, is measured by the Gibbs free - energy change, ΔG . The more negative the value of ΔG , the greater the tendency for the reaction to go. For example, consider the following reaction at 25 ° C:

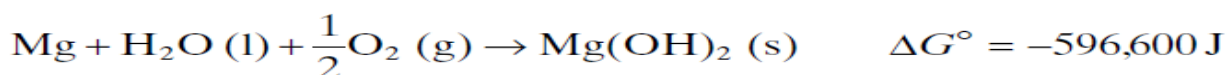

The large negative value of ΔG° (reactants and products in standard states) indicates a pronounced tendency for magnesium to react with water and oxygen. On the other hand, we have

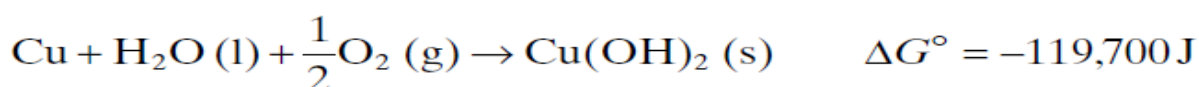

The reaction tendency is less. Or we can say that the corrosion tendency of copper in aerated water is not as pronounced as that of magnesium. Finally, we have

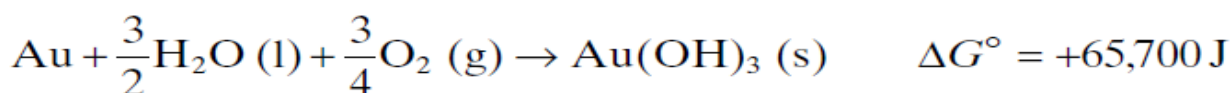

The free energy is positive, indicating that the reaction has no tendency to go at all; and gold, correspondingly, does not corrode in aqueous media to form $\text{Au}(\text{OH})_3$.

In view of the electrochemical mechanisms of corrosion, the tendency for a metal to corrode can also be expressed in terms of the electromotive force (emf). Since electrical energy is expressed as the product of volts by coulombs (joules, J), the relation between ΔG in joules and emf in volts, E , is defined by

$$\Delta G = -n F E$$

Where n is the number of electrons (or chemical equivalents) taking part in the reaction, and F is the Faraday (96,500 C/eq). Accordingly, the greater the value of E for any cell, the greater the tendency for the overall reaction of the cell to go. This applies to any of the types of cells described earlier. *The cell potential tells us the maximum work (maximum energy) that the cell can supply.*

Example:

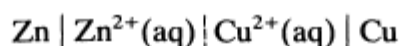

which means we consider the cell reaction as

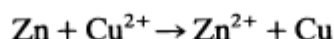

The half-reactions are represented by

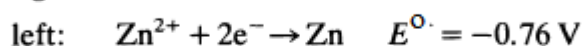
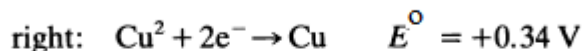

If the aqueous species have unit activity, then E° values may be used and

$$E_{\text{cell}}^{\circ} = +0.34 - (-0.76) = +1.10 \text{ V}$$

The corresponding ΔG° value is

$$\Delta G^{\circ} = -2.20F = -212 \text{ kJ mol}^{-1}$$

which is negative. This result shows that the reaction proceeds spontaneously as written.

The equivalent of the Nernst equation for the whole cell is

$$E_{\text{cell}} = E_{\text{cell}}^{\circ} + \frac{RT}{2F} \ln \frac{a_{\text{Cu}^{2+}}}{a_{\text{Zn}^{2+}}}$$

CALCULATING THE HALF - CELL POTENTIAL — THE NERNST EQUATION

The general reaction for a galvanic cell

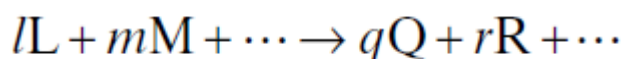

meaning that l moles of substance L plus m moles of substance M, and so on, react to form q moles of substance Q, r moles of substance R, and so on. The corresponding change of Gibbs free energy, ΔG , for this reaction is given by the difference in molal free energy of products and reactants, where G_Q represents the molal free energy of substance Q, and so on.

$$\Delta G = (qG_Q + rG_R + \dots) - (lG_L + mG_M + \dots) \quad 1$$

A similar expression is obtained for each substance in the standard state or arbitrary reference state, where the symbol G° indicates standard molal free energy:

$$\Delta G^\circ = (qG_Q^\circ + rG_R^\circ + \dots) - (lG_L^\circ + mG_M^\circ + \dots) \quad 2$$

If a_L is the corrected concentration or pressure of substance L, called its activity, the difference of free energy for L in any given state and in the standard state is related to a_L by the expression

$$l(G_L - G_L^\circ) = lRT \ln a_L = RT \ln a_L^l$$

where R is the gas constant (8.314 J/deg - mole), and T is the absolute temperature (degrees Celsius + 273.16). Subtracting (2) from (1) and equating to corresponding activities, we have the expression

$$\Delta G - \Delta G^\circ = RT \ln \frac{a_Q^q \cdot a_R^r \cdots}{a_L^l \cdot a_M^m \cdots} \quad 3$$

When the reaction is at equilibrium, there is no tendency for it to go, $\Delta G = 0$, And

$$\frac{a_Q^q \cdot a_R^r \cdots}{a_L^l \cdot a_M^m \cdots} = K$$

where K is the equilibrium constant for the reaction. Hence

$$\Delta G^\circ = -RT \ln K$$

On the other hand, when all the activities of reactants and products are equal to unity, the logarithm term becomes zero ($\ln 1 = 0$), and $\Delta G = \Delta G^\circ$. Since $\Delta G = -nFE$, it follows that $\Delta G^\circ = -nFE^\circ$,

where E° is the emf when all reactants and products are in their standard states (activities equal to unity). Corresponding to (3), we have

$$E = E^\circ - \frac{RT}{nF} \ln \frac{a_Q^q \cdot a_R^r \cdots}{a_L^l \cdot a_M^m \cdots}$$

This is the *Nernst equation*, which expresses the exact emf of a cell in terms of activities of products and reactants of the cell. The activity, a_L , of a dissolved substance L is equal to its concentration in *moles per thousand grams of water (molality)* multiplied by a correction factor, γ , called the activity coefficient. The activity coefficient is a function of temperature and concentration and, except for very dilute solutions, must be determined experimentally. If L is a gas, its activity is equal to its fugacity, approximated at ordinary pressures by the pressure in atmospheres. The activity of a pure solid is arbitrarily set equal to unity. Similarly, for water, with concentration essentially constant throughout the reaction, the activity is set equal to unity. Since it is more convenient to work with logarithms to the base 10, the value of the coefficient RT/F is multiplied by the conversion factor 2.303. Then, from the value of $R = 8.314 \text{ J/deg} \cdot \text{mole}$, $T = 298.2 \text{ K}$, and $F = 96,500 \text{ C/eq}$, the coefficient $2.303 RT/F$ at 25° C becomes 0.0592 V . This coefficient appears frequently in expressions representing potentials or emf.

$$E = E^\circ - \frac{0.0592}{n} \log \frac{a_Q^q \cdot a_R^r \cdots}{a_L^l \cdot a_M^m \cdots}$$

Since the emf of a cell is always the algebraic sum of two electrode potentials or of two half - cell potentials, it is convenient to calculate each electrode potential separately. For example, for the electrode reaction

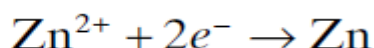

we have
$$\phi_{\text{Zn}} = \phi_{\text{Zn}}^\circ - \frac{RT}{2F} \ln \frac{(\text{Zn})}{(\text{Zn}^{2+})}$$

where (Zn^{2+}) represents the activity of zinc ions (molality \times activity coefficient); (Zn) is the activity of metallic zinc, the latter being a pure solid and equal, therefore, to unity; and ϕ_{Zn}° is the standard potential of zinc (equilibrium potential of zinc in contact with Zn^{2+} at unit activity).

ELCTRODE POTENTIAL

- The absolute value of electrode potential *cannot be measured*.
- In order to measure the potential difference across the metal/solution interface of interest, we must choose one electrode as *reference electrode*.
- The relative electrode potential can be obtained by measuring the electrode potential vs. a *standard reference electrode*.
- Internationally, a *standard hydrogen electrode (SHE)*, which potential is defined to be zero, is used as a standard reference electrode.

There are several types of reference electrode:

① *Standard hydrogen electrode (SHE)*

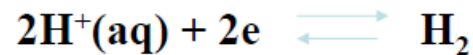
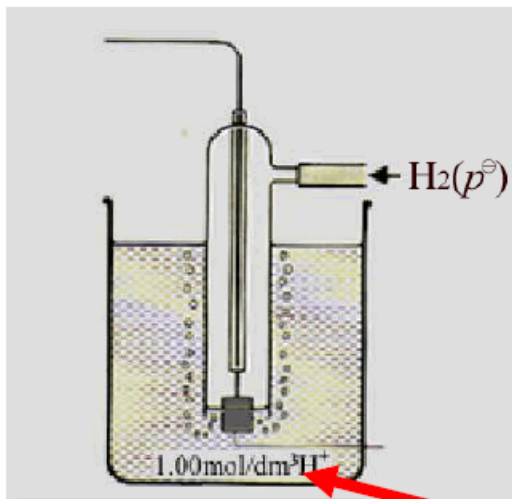
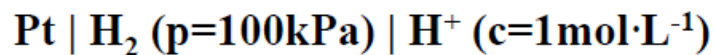

$$c = 1 \text{ mol}\cdot\text{L}^{-1} \quad p_{\text{H}_2} = p^{\theta} = 100 \text{ kPa}$$

$$\text{Define: } \phi^{\theta}(\text{H}^+/\text{H}_2) = 0.0\text{V}$$

Platinized Pt,

H_2 is constantly bubbled into a 1 M HCl solution

② Saturated calomel electrode (SCE)

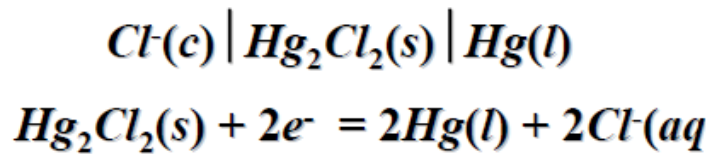
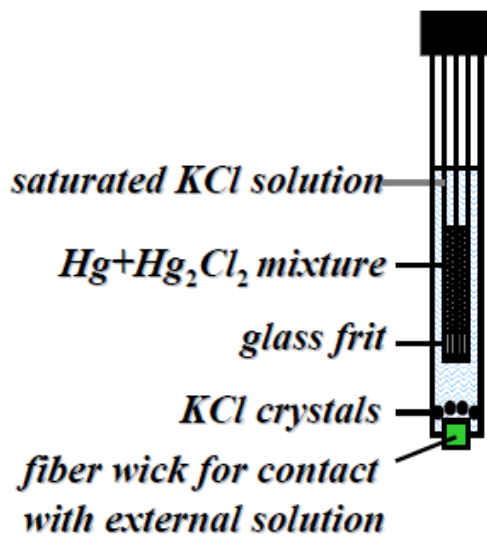

0.242 V vs. SHE

$$\phi(Hg_2Cl_2/Hg) = \phi^\theta(Hg_2Cl_2/Hg) - \frac{RT}{nF} \ln \frac{c(Cl^-)}{c^\theta}$$

③ Silver-silver chloride electrode

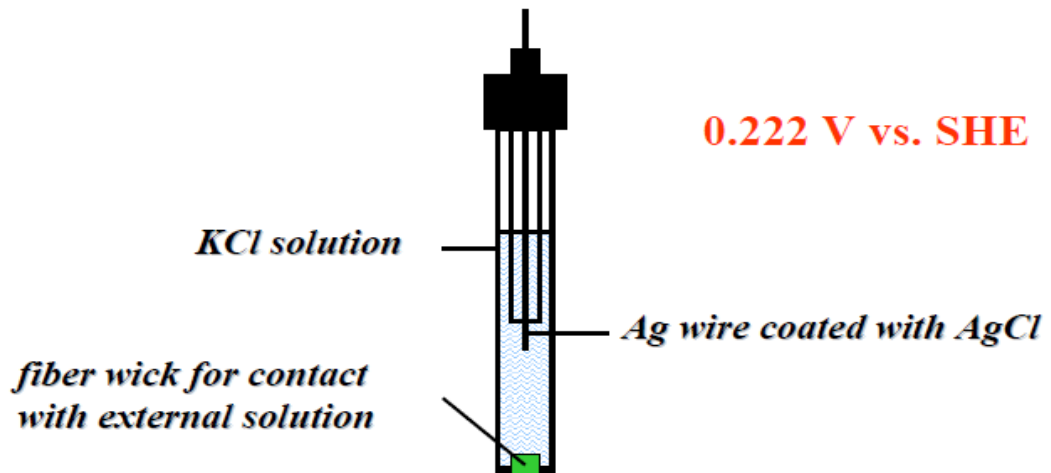

0.222 V vs. SHE

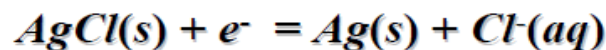

$$\phi(AgCl/Ag) = \phi^\theta(AgCl/Ag) - \frac{RT}{nF} \ln \frac{c(Cl^-)}{c^\theta}$$

$$\phi^\theta(AgCl/Ag) = 0.222 V$$

Standard electrode potential

- The standard electrode potential (ϕ^0) is the potential under standard state conditions
- For an electrochemical cell, **standard state conditions** are:
 - solutes at 1 M concentrations
 - gases at 1 atm partial pressure
 - solids and liquids in pure form
 - all at some specified temperature, usually 298 K

The activities of all these species are 1

The standard potential of most half cell reactions can be obtained in the handbook

The Electromotive Force Series

An ordered listing of the standard half-cell potentials is called the **electromotive force (emf) series**

The metals located near the top (positive end) of the emf series are more chemically stable than metals located near the bottom (negative end). Said simply, metals near the top of the emf series are less prone to corrosion.

Reaction	E^0 (V vs. SHE)	
$\text{Au}^{3+} + 3e^- \rightarrow \text{Au}$	+1.498	Noble ↑
$\text{Pt}^{2+} + 2e^- \rightarrow \text{Pt}$	+1.18	
$\text{Pd}^{2+} + 2e^- \rightarrow \text{Pd}$	+0.951	
$\text{Hg}^{2+} + 2e^- \rightarrow \text{Hg}$	+0.851	
$\text{Ag}^+ + e^- \rightarrow \text{Ag}$	+0.800	
$\text{Cu}^+ + e^- \rightarrow \text{Cu}$	+0.521	
$\text{Cu}^{2+} + 2e^- \rightarrow \text{Cu}$	+0.342	
$2\text{H}^+ + 2e^- \rightarrow \text{H}_2$	0.000	
$\text{Pb}^{2+} + 2e^- \rightarrow \text{Pb}$	-0.126	
$\text{Sn}^{2+} + 2e^- \rightarrow \text{Sn}$	-0.138	
$\text{Mo}^{3+} + 3e^- \rightarrow \text{Mo}$	-0.200	
$\text{Ni}^{2+} + 2e^- \rightarrow \text{Ni}$	-0.257	
$\text{Co}^{2+} + 2e^- \rightarrow \text{Co}$	-0.28	
$\text{Cd}^{2+} + 2e^- \rightarrow \text{Cd}$	-0.403	
$\text{Fe}^{2+} + 2e^- \rightarrow \text{Fe}$	-0.447	
$\text{Ga}^{3+} + 3e^- \rightarrow \text{Ga}$	-0.549	
$\text{Ta}^{3+} + 3e^- \rightarrow \text{Ta}$	-0.6	
$\text{Cr}^{3+} + 3e^- \rightarrow \text{Cr}$	-0.744	
$\text{Zn}^{2+} + 2e^- \rightarrow \text{Zn}$	-0.762	
$\text{Nb}^{3+} + 3e^- \rightarrow \text{Nb}$	-1.100	
$\text{Mn}^{2+} + 2e^- \rightarrow \text{Mn}$	-1.185	
$\text{Zr}^{4+} + 4e^- \rightarrow \text{Zr}$	-1.45	
$\text{Hf}^{4+} + 4e^- \rightarrow \text{Hf}$	-1.55	
$\text{Ti}^{2+} + 2e^- \rightarrow \text{Ti}$	-1.630	
$\text{Al}^{3+} + 3e^- \rightarrow \text{Al}$	-1.662	
$\text{U}^{3+} + 3e^- \rightarrow \text{U}$	-1.798	
$\text{Be}^{2+} + 2e^- \rightarrow \text{Be}$	-1.847	
$\text{Mg}^{2+} + 2e^- \rightarrow \text{Mg}$	-2.372	
$\text{Na}^+ + e^- \rightarrow \text{Na}$	-2.71	
$\text{Ca}^{2+} + 2e^- \rightarrow \text{Ca}$	-2.868	
$\text{K}^+ + e^- \rightarrow \text{K}$	-2.931	
$\text{Li}^+ + e^- \rightarrow \text{Li}$	-3.040	↓ Active

The limitations of emf series

The emf series is applied to pure metals in their own ions at unit activity. The relative ranking of metals in the emf series is not necessarily the same (and is usually not the same) in other media (such as seawater, groundwater, sulfuric acid, artificial perspiration). The emf series is applied to pure metals only and not to metallic alloys. The relative ranking of metals in the emf series gives corrosion tendencies but provides no information on corrosion rates.

Galvanic Series

Because of the limitations of the Emf Series for predicting galvanic relations, and also because alloys are not included, the *Galvanic Series* has been developed.

- The Galvanic Series is an arrangement of metals and alloys in accord with their actual measured potentials in a given environment.
- The Galvanic Series for metals in seawater is given in Figure below.
- Some metals occupy two positions in the Galvanic Series, depending on whether they are active or passive, whereas in the Emf Series only the active positions are possible.

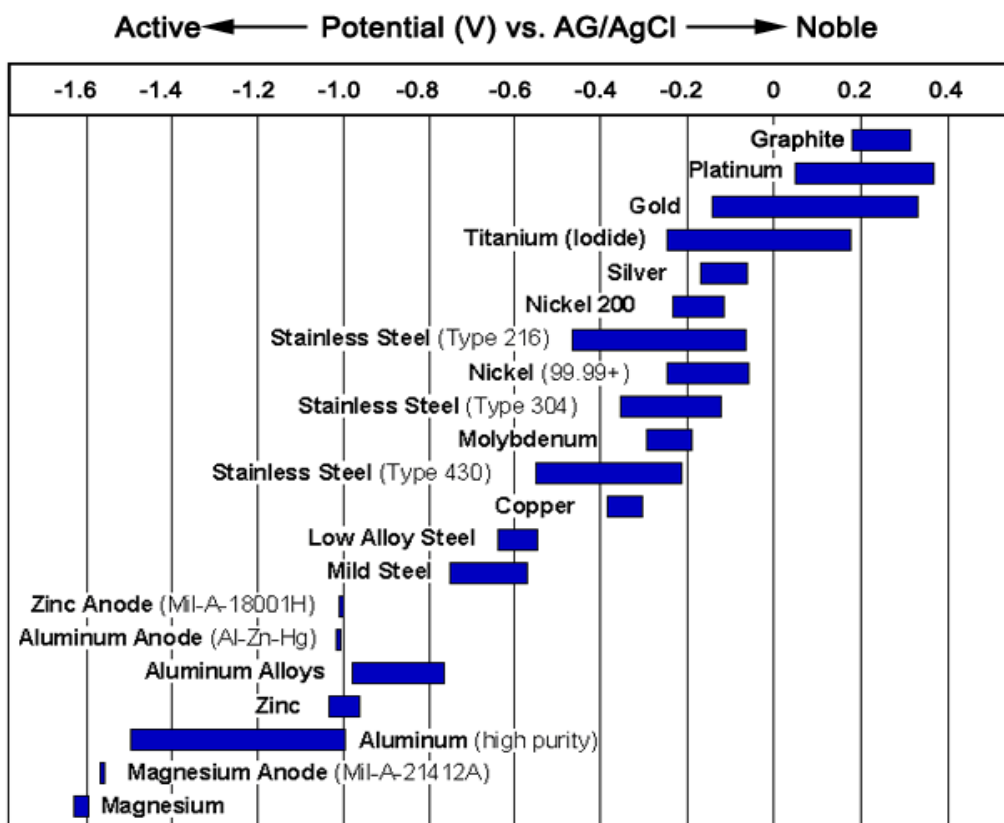

MEASUREMENT OF pH

Hydrogen ion activity is commonly expressed, for convenience, in terms of pH, defined as

$$\text{pH} = -\log(\text{H}^+)$$

Hence, for the half - cell reaction, with the pressure of hydrogen equal to 1 atm, we have

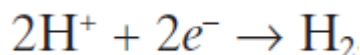

$$\phi_{\text{H}_2} = -0.0592 \text{ pH}$$

Example:

Consider a galvanic cell that uses the reaction:

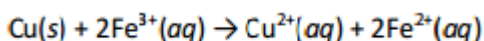

$$[\text{Fe}^{3+}] = 1.0 \times 10^{-4} \text{ M} \quad [\text{Cu}^{2+}] = 0.25 \text{ M} \quad [\text{Fe}^{2+}] = 0.20 \text{ M}$$

What is the potential of a cell at 25 °C that has the following ion concentrations? What is K, reaction quotient (equilibrium constant)?

Solution:

$$K = \frac{[\text{Cu}^{2+}] \times [\text{Fe}^{2+}]^2}{[\text{Fe}^{3+}]^2} = \frac{(0.25) \times (0.20)^2}{(0.00010)^2} = 1.00 \times 10^6$$

Notice that solid copper is omitted.

Cell is not under standard conditions, so the Nernst Equation must be used:

$$E = E^\circ_{\text{cell}} - \frac{0.0592}{n} \log K$$

$$E^\circ_{\text{cell}} = E^\circ_{\text{cathode}} - E^\circ_{\text{anode}} \quad (\text{What should it be under standard conditions})$$

$$E^\circ_{\text{cell}} = 0.77 \text{ V} - 0.34 \text{ V} = 0.43 \text{ V}$$

Total of 2 electrons transferred, $n = 2$

$$E = 0.43 \text{ V} - \frac{0.0592 \text{ V}}{2} \log(1.00 \times 10^6) = 0.43 \text{ V} - 0.0296 \text{ V} \times 6 = 0.25 \text{ V}$$

Example:

Calculate the EMF of the cell

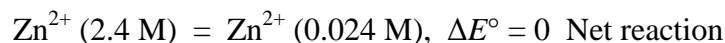
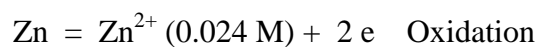
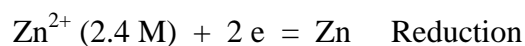

Solution

Using the Nernst equation:

$$\Delta E = \Delta E^\circ - \frac{0.0592}{2} \log \frac{0.024}{2.4} = (-0.296)(-2) = 0.0592 \text{ V}$$

The Zn^{2+} ions try to move from the concentrated half-cell to a dilute solution. That driving force gives rise to 0.0592 V.

Example:

Calculate the voltage produced by the cell $\text{Sn}_{(s)}|\text{Sn}^{2+}||\text{Ag}^+|\text{Ag}_{(s)}$ at 25°C given:

$$[\text{Sn}^{2+}] = 0.15 \text{ M}, [\text{Ag}^+] = 1.7 \text{ M}$$

Solution:

Write the Nernst Equation for 25°C:

$$\Delta E = \Delta E^\circ - \frac{0.0592}{n} \log K$$

Calculate E° for the cell:

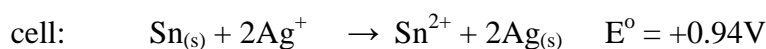
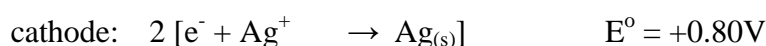
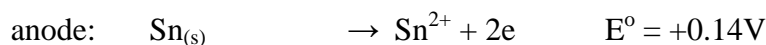

Write the expression for K: $K = [\text{Sn}^{2+}]/[\text{Ag}^+]^2$ (concentrations of solids = 1)

Write the Nernst Equation for this example: $\Delta E = \Delta E^\circ - \frac{0.0592}{n} \log \frac{[Sn^{2+}]}{[Ag^+]^2}$

Substitute the values: $\Delta E = 0.94 - \frac{0.0592}{2} \log \frac{[0.15]}{[1.7]^2} = 0.98 V$

$E > E^\circ$, and positive, so the cell reaction has a greater tendency to take place at these concentrations.

EXAMPLE

Calculate the cell potential for the following cell as a function of pH.



Solution

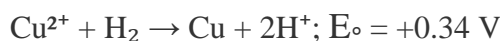
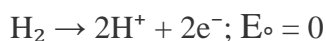

$$E_{Cu^{2+}/Cu} = E^\circ - \frac{RT}{nF} \ln \frac{1}{[Cu^{+2}]} = 0.34 V$$

$$E_{H_2/H^+} = E^\circ - \frac{RT}{nF} \ln \frac{[H^+]}{1} = 0 + 0.059 pH$$

$$E_{Cell} = 0.34 + 0.059 pH$$

POURBAIX DIAGRAM

- *Pourbaix diagram*, also known as a potential/pH diagram, E_H -pH diagram or a pE/pH diagram, maps out possible stable (equilibrium) phases of an aqueous electrochemical system.
- Pourbaix diagram can be read much like a standard phase diagram with a different set of axes.
- The Nernst equation forms the basis of developing thermodynamic “stability” of Pourbaix Diagrams

- Thus, a Pourbaix Diagram is constructed by looking at the thermodynamics of a system on E vs pH axes.
- Pourbaix Diagram is a thermodynamic map of corrosion, passivity and nobility of a particular metal as a function of system pH and potential.
- In constructing Pourbaix diagrams, the concentration of the ionic species at the boundary between a solid substance and a dissolved substance is usually taken as a very low value, such as 10^{-6} M.

POURBAIX DIAGRAM FOR WATER

Each line of a Pourbaix diagram represents conditions of thermodynamic equilibrium for some reaction. The Pourbaix diagram for water is presented in Fig.

- Above line *b*, oxygen is evolved in accord with the reaction. For this equilibrium, the relationship between potential and pH is, from the Nernst equation,

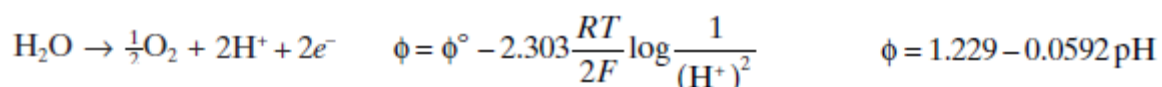

- Above line *b*, defined by this equation, oxygen is evolved at the surface of an immersed electrode. Below this line, water is stable. Below line *a*, hydrogen is evolved in accord with the reaction

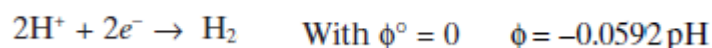

- Below line *a*, represented by this equation, hydrogen gas is evolved from the surface of an immersed electrode. Between lines *a* and *b*, water is stable.

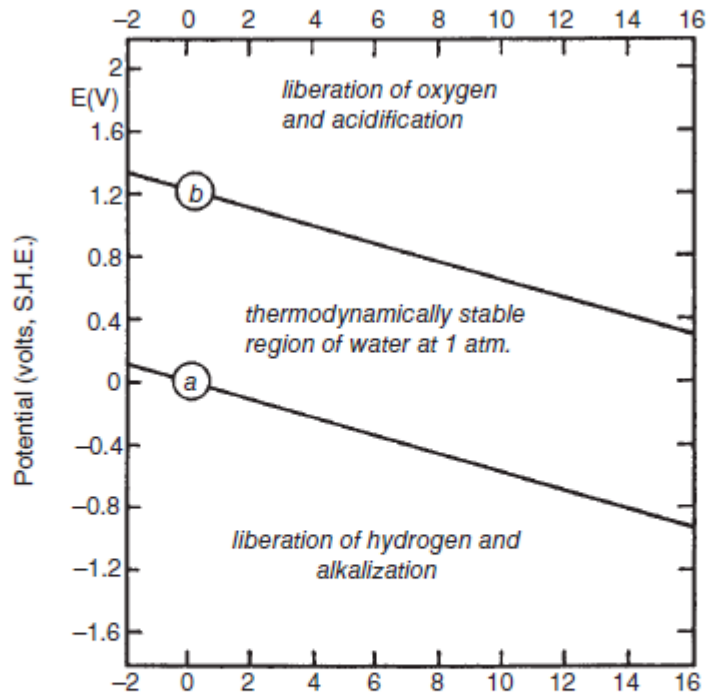

Figure Pourbaix diagram for water at 25°C, showing the oxygen line, *b*, above which oxygen is evolved, and the hydrogen line, *a*, below which hydrogen is evolved, from the surface of an immersed electrode. Between these two lines, water is stable. (M. Pourbaix, *Atlas of Electrochemical Equilibria in Aqueous Solutions*, 2nd English edition, p. 100, copyright NACE International 1974 and CEBELCOR.)

POURBAIX DIAGRAM FOR IRON

- A horizontal line represents a reaction that does not involve pH; that is, neither H^+ nor OH^- is involved, as in the reaction, For this equilibrium, using the Nernst equation, we obtain

$$Fe^{2+} + 2e^- \rightarrow Fe \quad \phi = \phi^\circ - 2.303 \frac{RT}{nF} \log \frac{1}{(Fe^{2+})} \quad \phi = -0.440 + 0.0296 \log (Fe^{2+})$$

If (Fe^{2+}) is taken as 10^{-6} , then $\phi = -0.617V$, a horizontal line on the Pourbaix diagram.

- A vertical line involves H^+ or OH^- , but not electrons. In Figure, the vertical line separating Fe^{3+} from Fe_2O_3 corresponds to this reaction.

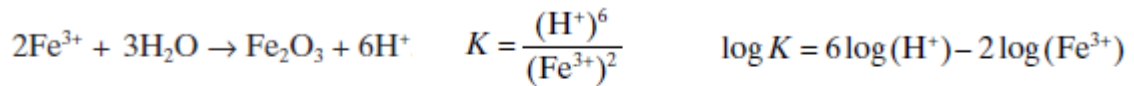

$$\log K = -6 \text{pH} - 2 \log(\text{Fe}^{3+})$$

Since $\Delta G^\circ = -RT \ln K$ and $\Delta G^\circ = -8240 \text{ J/mole}$, we obtain

$$\log K = 1.43 \quad \log(\text{Fe}^{3+}) = -0.72 - 3 \text{pH}$$

$$\text{Taking } (\text{Fe}^{3+}) = 10^{-6}, \text{ we have} \quad \text{pH} = 1.76.$$

In the Pourbaix diagram for iron, Fig. 4.2, the vertical line at pH 1.76 represents the equilibrium reaction, $2\text{Fe}^{3+} + 3\text{H}_2\text{O} \rightarrow \text{Fe}_2\text{O}_3 + 6\text{H}^+$. To the right of this line (i.e., at $\text{pH} > 1.76$), Fe_2O_3 is the stable phase; and this oxide, as a protective film, would be expected to provide some protection against corrosion. To the left of this line (i.e., at $\text{pH} < 1.76$), ferric ions in solution are stable, and corrosion is expected to take place without any protection afforded by a surface oxide film.

- A sloping line involves H^+ , OH^- , and electrons.

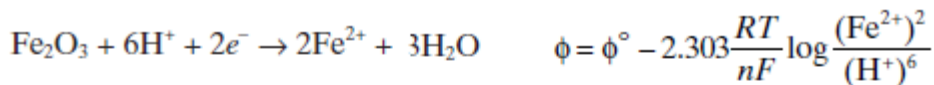

Since $\phi^\circ = 0.728 \text{ V}$ and $n = 2$, we get

$$\begin{aligned} \phi &= 0.728 - 0.0296 \log(\text{Fe}^{2+}) \\ \phi &= 0.728 - \frac{0.0592}{2} \log(\text{Fe}^{2+})^2 + \frac{0.0592}{2} \log(\text{H}^+)^6 \\ \phi &= 0.728 - 0.0592 \log(\text{Fe}^{2+}) - 0.1776 \text{pH} \end{aligned}$$

Taking $(\text{Fe}^{2+}) = 10^{-6}$, we obtain

$$\phi = 1.082 - 0.1776 \text{pH}$$

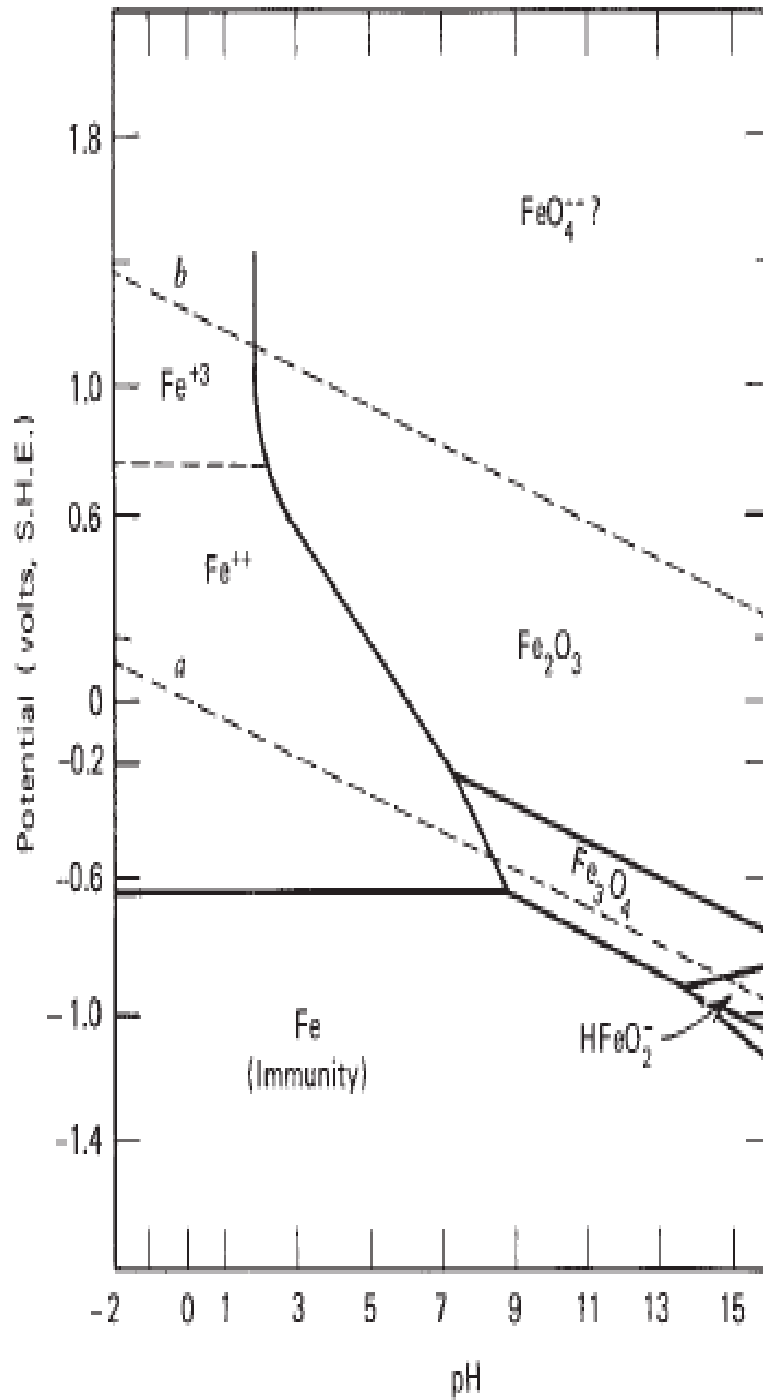
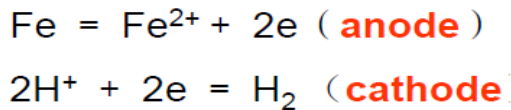

Figure Pourbaix diagram for the iron-water system at 25°C, considering Fe, Fe₃O₄, and Fe₂O₃ as the only solid substances.

Case study and application of Pourbaix Diagram:

- **Point A:** Fe and H₂ are stable, Fe don't corrode.
- **Point B:** Fe²⁺ and H₂ are stable, Fe occur corrosion with evolution of H₂.



- **Point C:** Fe²⁺ and H₂O are stable, Fe occur corrosion with reduction of O₂.

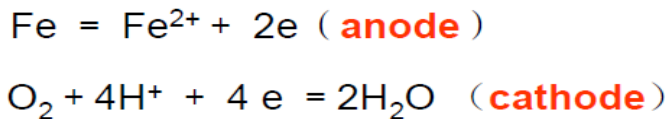

At Point B: a pH of 6.0 and an electrode potential of -0.4 V vs. SHE corresponds to a region of corrosion as Fe²⁺ ions.

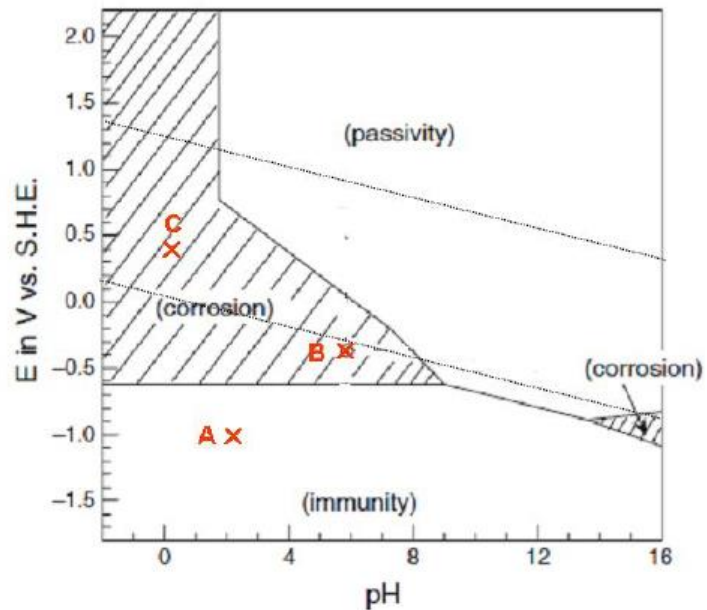
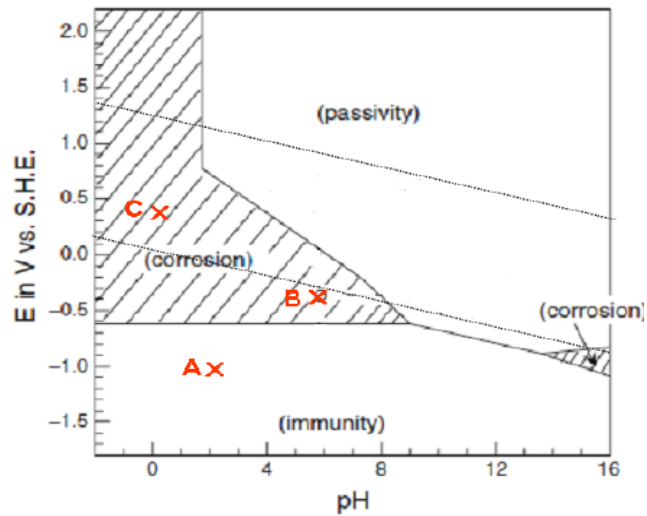

Please suggest any methods for corrosion protection?...

(1) **Lower potential:** If the electrode potential is changed in the negative direction to a value below -0.7 V SHE, the iron electrode is forced into a region of immunity. This process is called *cathodic protection*

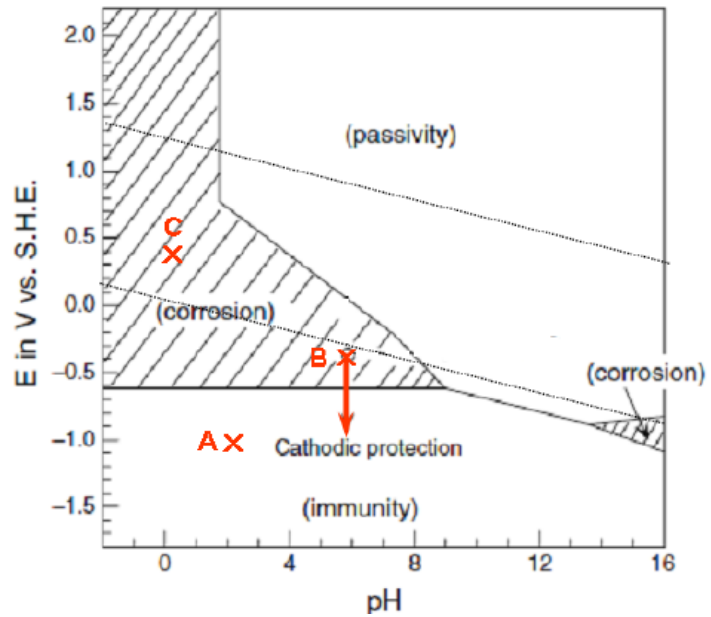

(2) **Enhance potential:** If the electrode potential is changed in the positive direction to values above approximately 0.0 V vs. SHE, the iron electrode is forced into a region of passivity. This process is called *anodic protection*

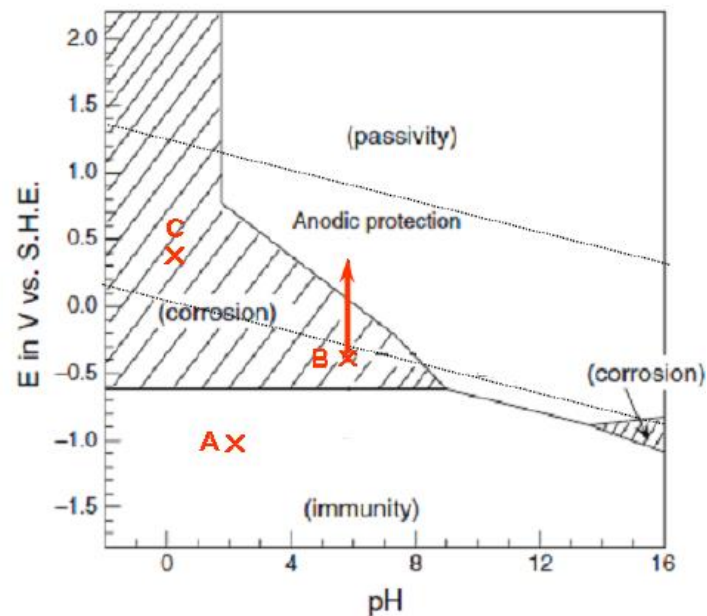

(3) **Increase pH:** The third method of protection is to change the pH of the aqueous solution. If the pH is increased to approximately 8 or higher, the iron electrode will then also reside in a region of passivity

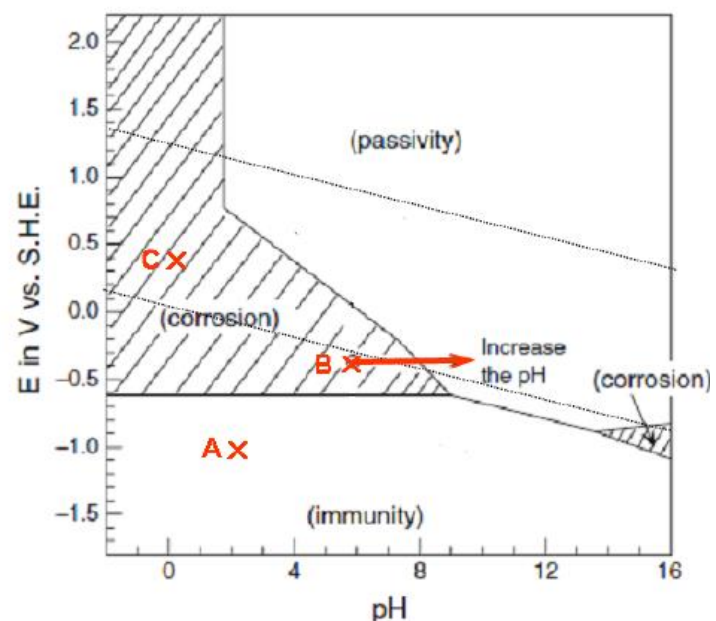

Chapter 3

POLARIZATION AND CORROSION RATES

POLARIZATION

When there is no net current flows from an electrode, then this electrode is at equilibrium state and its potential is the equilibrium potential (E°). When net current flows to or from its surface, the potential changes from E° to E_i , the electrode is then said to be polarized and the process is termed as polarization. Polarization is measured in volts as follows:

$$\eta = E_i - E^\circ \quad (1)$$

Where:

η = The overvoltage, and E_i = The polarization potential

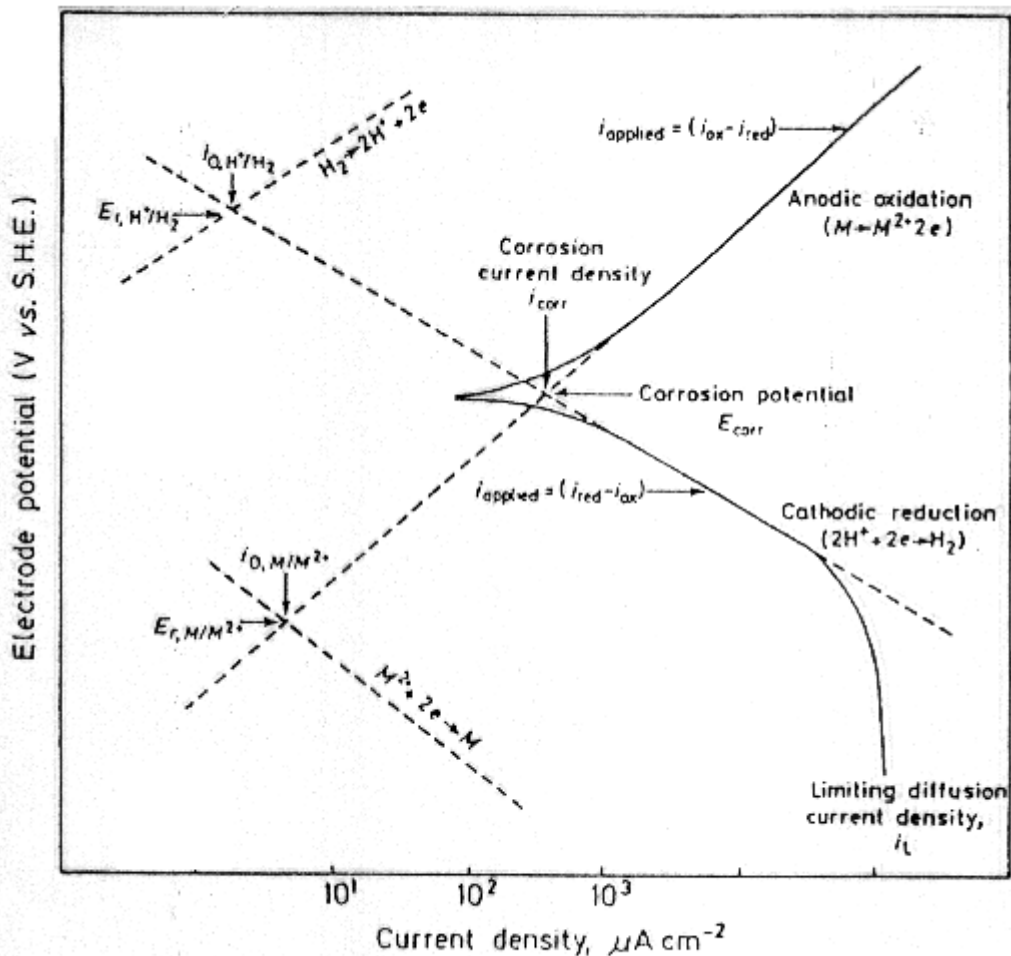

Fig. Electrode Kinetic Behavior of a Metal (M) in Reducing Acid

Above Figure shows polarization curves (E vs. log i) for the corrosion of metal in a reducing acid in which there are two exchange processes involving oxidation of M/M^+ and reducing H^+/H_2 .

Polarization is divided into three main types:

1. ACTIVATION POLARIZATION (η_A):

This polarization is caused by a slow electrode reaction or stated in another way. The reaction at the electrode requires activation energy in order to go. The most important is that of hydrogen ion reduction at the cathode⁽³⁶⁾; reaction might be considered as:



Stage (1) occurs rapidly, whereas stage (2) is generally the slower and rate-controlling step.

The activation overpotential, and hence the activation energy varies exponentially with the rate of charge transfer per unit area of electrode surface, as defined by the well-known Tafel equation⁽⁷⁰⁾:

$$\eta_A = \pm \beta \log \left(\frac{i}{i_o} \right) \quad (3)$$

Where:

i = The current density, and

$$\beta = \text{The Tafel constant being equal to } \left(2.303 \frac{R T}{\alpha Z F} \right)$$

The Tafel constant (β) varies with the nature of the electrode process and with the nature of the solution. Thus (η_A) will be linearly related to (log i) at overpotential greater than 0.05 V and the position of the curve will be dependent on the equilibrium exchange current density (i_o), the transfer coefficient (α) and the number of electrons (z) involved in one act of the rate determining step. The

Tafel equation for a cathodic process can be expressed in the form:

$$\eta_{A,c} = \frac{R T}{\alpha z F} \ln i_o - \frac{R T}{\alpha z F} \ln i_c \quad (4)$$

Similarly for the anodic process:

$$\eta_{A,a} = -\frac{RT}{(1-\alpha)zF} \ln i_o + \frac{RT}{(1-\alpha)zF} \ln i_a \quad (5)$$

HYDROGEN OVERPOTENTIAL

The polarization term that controls the corrosion rate of many metals in deaerated water and in nonoxidizing acids is hydrogen overpotential. In accord with the previously discussed definition of polarization, hydrogen overpotential is the difference of potential between a cathode at which hydrogen is being evolved, E_i , and a hydrogen electrode at equilibrium in the same solution; that is,

$$\eta_{H_2} = E_i - E_{H_2}^o = E_i - (-0.059 \text{ pH}) = E_i + 0.059 \text{ pH}$$

2. CONCENTRATION POLARIZATION (η_c):

Concentration polarization is obtained when the rate of an electrode reaction is dependent on mass transfer, i.e. the rate at which the reactant is transported to the surface of the electrode and the rate at which the product is transported away from the electrode. For concentration polarization reaction current is given by Fick's law:

$$|I| = z F D A \left(\frac{dC}{dx} \right) \quad (6)$$

Or its equivalent

$$|I| = z F D A \left(\frac{C_b - C_s}{\delta} \right) \quad (6.a)$$

The limiting current, i.e., the maximum current under diffusion control is obtained when $C_s = 0$.

$$|I_L| = z F D A \frac{C_b}{\delta} \quad (6.b)$$

Or

$$|I_L| = z F A k C_b \quad (7)$$

Where the mass transfer coefficient is defined as:

$$k = \frac{D}{\delta} \quad (8)$$

The concentration polarization can also be expressed as:

$$\eta_c = \frac{R T}{z F} \ln \left(\frac{C_s}{C_b} \right) \quad (9) \quad \text{Or} \quad \boxed{\eta_c = \frac{R T}{z F} \ln \left(1 - \frac{I}{I_L} \right)} \quad (10)$$

Where: F = Faraday's constant (columbs/mole), D = Diffusivity (cm²/s), δ = Diffusion layer thickness (cm), C_b = Bulk concentration (gmole/cm³), C_s = Surface concentration (gmole/cm³), A = Surface area (cm²). From equation (10) it can be seen that:

1. The term $\left(1 - \frac{I}{I_L} \right)$ is equivalent to the term $\left(\frac{C_s}{C_b} \right)$ in equation (9).
2. When I is very small in comparison with I_L, the concentration polarization is negligible.
3. When I approach I_L in magnitude, concentration polarization approaches infinity.

3. RESISTANCE POLARIZATION (η_R):

The resistance polarization is the ohmic potential drop through a portion of the electrolyte surrounding the electrode, through a metal reaction product film on the surface or both. An ohmic potential drop always occurs between the working electrode and the capillary tip of reference electrode. The ohmic (i.e., solution) IR drop is given by:

$$IR_{\text{soln.}} = i \rho l = i l / k \quad (11)$$

Where: ρ = The specific resistance (i.e. resistivity) ($\Omega \cdot \text{cm}$), k = The conductivity ($\Omega^{-1} \cdot \text{cm}^{-1}$) or ($\text{S} \cdot \text{cm}^{-1}$); S = Siemens, l = The solution gap between the capillary tip and the working electrode (cm). Resistance polarization is important only at high current densities or in high resistance electrolyte solution. All of these three types of polarization will be present to a greater or less extent in most corrosion reactions.

$$\eta_{\text{Total}} = \eta_A + \eta_C + \eta_R \quad (12)$$

But if one is more influential than the others, then it will control the reaction rate.

HOW POLARIZATION MEASURED

Polarization can be measured using electrochemical corrosion cell and potentiostat as shown in figure 1. Electrical connections are shown in figure 2.

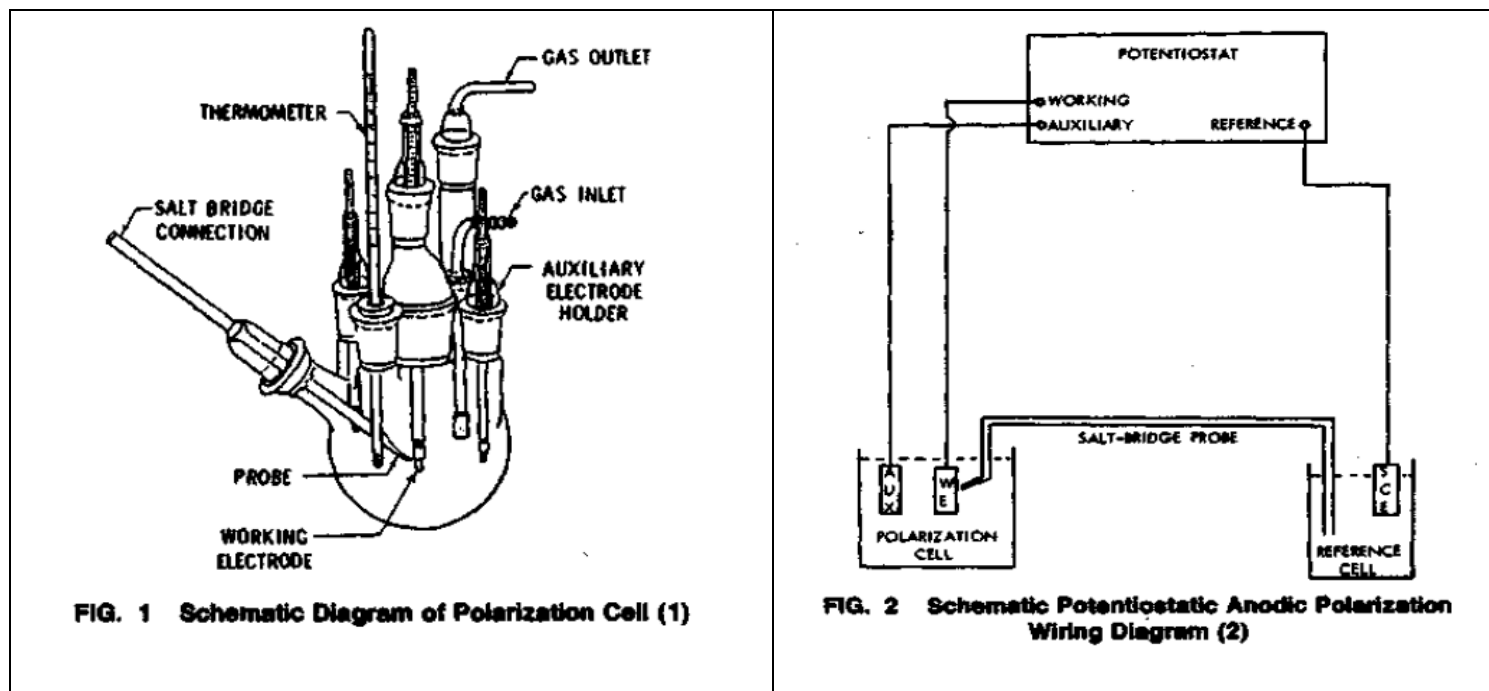

FIG. 1 Schematic Diagram of Polarization Cell (1)

FIG. 2 Schematic Potentiostatic Anodic Polarization Wiring Diagram (2)

Polarization corrosion cell was equipped with several necks, which can be used according to the test conditions:

1. One for the working electrode (metal or test sample).
2. One for reference electrode (SCE, SHE, etc), for potential measurements.
3. One for thermometer, for temperature control.
4. Counter electrodes.

CORROSION RATE MEASUREMENTS FROM POLARIZATION CURVE

Besides the weight loss technique there are other techniques used in corrosion rate measurements.

1. LINEAR POLARIZATION TECHNIQUE

The linear polarization technique in principle is a convenient and rapid way for determining corrosion rates. The technique was started by *Wanger and Traud* who stated that the corrosion process with two coupled electrochemical reactions under activation control can be represented by:

$$i = i_{corr.} \left[\exp\left(\frac{\eta}{b_a}\right) - \exp\left(-\frac{\eta}{b_c}\right) \right] \quad (13)$$

Equation 13 is derived and simplified by *Stern and Geary* for relatively small increment of the exponent (i.e., for potential within about 10 mV of the corrosion potential). The slope of this linear polarization is related to the kinetic parameters of the system as follows:

$$\frac{\Delta E}{\Delta i_{app.}} = \frac{b_a b_c}{2.303 I_{corr.} (b_a + b_c)} \quad (14)$$

Where; b_a & b_c are the anodic and cathodic Tafel slopes respectively. The *Stern and Geary* required both anodic and cathodic slopes. For accurate measurement, it is necessary to determine the values of b_a and b_c . For fast corrosion rate calculation assume the values of Tafel slopes in the range of 120 mV, then equation 14 reduced to:

$$\frac{\Delta E}{\Delta i_{app.}} = \frac{0.026}{I_{corr.}} \Rightarrow I_{corr.} = \frac{0.026}{R_p} \quad (15)$$

The ratio of the derivative of the overpotential to the current, $\partial\eta/di$ when $\eta \rightarrow 0$, represents the resistance in Ohm's law and is often termed the charge-transfer resistance or the polarization resistance R_p .

$$R_p = d\eta/di \quad \text{for cathodic reaction from eq. 4} \quad \left[\frac{di}{d\eta} \right] = -i^{\circ} \frac{\alpha n F}{RT}$$

Example

The exchange current densities for a hydrogen-evolution reaction on three different metals are $5 \times 10^{-4} \text{ A/cm}^2$, $3 \times 10^{-7} \text{ A/cm}^2$, and $5 \times 10^{-11} \text{ A/cm}^2$, respectively. Calculate the current densities and the polarization resistances if the reactions proceed at $\eta = -0.08 \text{ V}$ versus SHE. The electrode surface area is 1 cm^2 and $\alpha = 0.5$.

Solution:

The polarization resistance for a given area of the electrode is given by:

$$R_p = \frac{\left(\frac{d\eta}{di}\right)}{A}$$

The simplified form of the Butler-Volmer equation for the cathodic reaction can be written as:

$$\left[\frac{di}{d\eta}\right] = -i^\circ \frac{\alpha n F}{RT}$$

The polarization resistance is calculated using the expression (A) and the given i° values:

$$R_p = \frac{1}{A} \frac{1}{\left[\frac{di}{d\eta}\right]} = -\frac{1}{A n F i^\circ} \quad (\text{A})$$

$$R_{p1} = 0.0513 \text{ k}\Omega$$

$$R_{p2} = 0.0513 \text{ k}\Omega$$

$$R_{p3} = 0.0513 \text{ k}\Omega$$

Example

Calculate the corrosion currents for the metals in **above** Example using the Stern-Geary equation for cathodic and anodic Tafel slopes of $b_c = -0.1 \text{ V}$ and $b_a = 0.1 \text{ V}$. Estimate the corrosion rates in mpy.

Solution:

Corrosion currents:

$$I_{\text{corr}} = \frac{b_a \times b_c}{2.3(b_a + b_c)} \times \frac{1}{R_p}$$

$$I_{\text{corr1}} = \frac{0.1 \text{ V} \times 0.1 \text{ V}}{2.3 \times (0.1 \text{ V} + 0.1 \text{ V})} \times \frac{1}{51.3 \Omega} = 4.24 \times 10^2 \mu\text{A/cm}^2$$

$$I_{\text{corr2}} = \frac{0.1 \text{ V} \times 0.1 \text{ V}}{2.3 \times (0.1 \text{ V} + 0.1 \text{ V})} \times \frac{1}{8.56 \times 10^4 \Omega} = 2.54 \times 10^{-1} \mu\text{A/cm}^2$$

$$I_{\text{corr3}} = \frac{0.1 \text{ V} \times 0.1 \text{ V}}{2.3 \times (0.1 \text{ V} + 0.1 \text{ V})} \times \frac{1}{5.13 \times 10^8 \Omega} = 4.20 \times 10^{-5} \mu\text{A/cm}^2$$

Corrosion rates:

$$\text{C.R}_1 = \frac{0.131 \times (4.24 \times 10^2) \times (\text{E.W}_1)}{d_1}$$

$$\text{C.R}_2 = \frac{0.131 \times (2.54 \times 10^{-1}) \times (\text{E.W}_2)}{d_2}$$

$$\text{C.R}_3 = \frac{0.131 \times (4.20 \times 10^{-5}) \times (\text{E.W}_3)}{d_3}$$

Example

If the slope of the polarization curve is $R_p = \Delta E / \Delta i = 2 \text{ mV}/\mu\text{A}/\text{cm}^2$ and the cathodic and anodic Tafel slopes are $b_c = -0.1 \text{ V}$ and $b_a = 0.1 \text{ V}$, calculate the corrosion rate of Ni ($d = 8.9 \text{ g}/\text{cm}^3$) in g/s.

Solution:

Using the Stern-Geary equation

$$I_{\text{corr}} = \frac{b_a \times b_c}{2.3(b_a + b_c)} \times \frac{\Delta i}{\Delta E} \quad I_{\text{corr}} = \frac{0.01 \text{ V}^2}{2.3 \times 0.2 \text{ V}} \times \frac{\mu\text{A}/\text{cm}^2}{2 \text{ mV}} \times \frac{1000 \text{ mV}}{1 \text{ V}} = I_{\text{corr}} = 10.87 \mu\text{A}/\text{cm}^2$$

$$\text{Because} \quad \frac{m}{t} = \frac{MI_{\text{corr}}}{nF} A$$

$$\text{CR} = \left[\frac{58.6934 \text{ g/mol}}{2 \text{ eq/mol}} \right] \times [10.87 \mu\text{A}/\text{cm}^2] \times \frac{1 \text{ eq}}{96,500 \text{ C}} \times 1 \text{ cm}^2 \times \frac{1 \text{ C/s}}{10^6 \mu\text{A}} = 3.3 \times 10^{-9} \text{ g/s}$$

Example

The linear polarization slope for a tin electrode measured in tomato juice is $5 \text{ mV}/(\mu\text{A}/\text{cm}^2)$. Calculate the corrosion rate in ($\text{g}/\text{m}^2 \text{ day}$). Assume $b_a = b_c = \pm 0.1 \text{ V}$.

Solution:

$$R_p = \frac{\Delta E}{\Delta i} = 5 \frac{\text{mV}}{\mu\text{A}/\text{cm}^2} \quad I_{\text{corr}} = \frac{b_a \times b_c}{2.3(b_a + b_c)} \times \frac{\Delta i}{\Delta E} \quad I_{\text{corr}} = \frac{0.01 \text{ V}^2}{0.46 \text{ V}} \times \frac{\mu\text{A}/\text{cm}^2}{5 \text{ mV}} \times \frac{1000 \text{ mV}}{1 \text{ V}}$$

$$I_{\text{corr}} = 4.348 \mu\text{A}/\text{cm}^2$$

$$\text{CR} = [4.348 \mu\text{A}/\text{cm}^2] \left[\frac{118.710 (\text{g/mol})}{2 (\text{eq/mol})} \right] \times \frac{1 \text{ cm}^2}{1 \times 10^{-4} \text{ m}^2} = 2.581 \times 10^6 \frac{\mu\text{Ag}}{\text{eq m}^2}$$

$$\text{CR} = 2.581 \times 10^6 \left(\frac{\mu\text{Ag}}{\text{eq m}^2} \right) \times \left(\frac{1 \text{ eq}}{96,487 \text{ C}} \right) \times \left(\frac{1 \text{ C}}{1 \times 10^6 \mu\text{As}} \right) \times \left(\frac{3600 \text{ s}}{1 \text{ h}} \right) \times \left(\frac{24 \text{ h}}{1 \text{ day}} \right) = 2.31 \text{ g}/\text{m}^2 \text{ day}$$

2. TAFEL EXTRAPOLATION TECHNIQUE

The Tafel extrapolation method uses data obtained from either cathodic or anodic polarization measurements. If the potential of electrode (with respect to the reference electrode) is plotted against the logarithm of applied current then a figure similar to that shown in Fig. is produced. The applied current polarization curve indicated by points and a solid line. At low currents the curve is non-linear; but at higher current it becomes linear on a semi-logarithmic plot. Applied cathodic current is related to cathodic and anodic current as:

$$i_{\text{app.}} = i_{\text{red.}} - i_{\text{oxd.}} \quad (15)$$

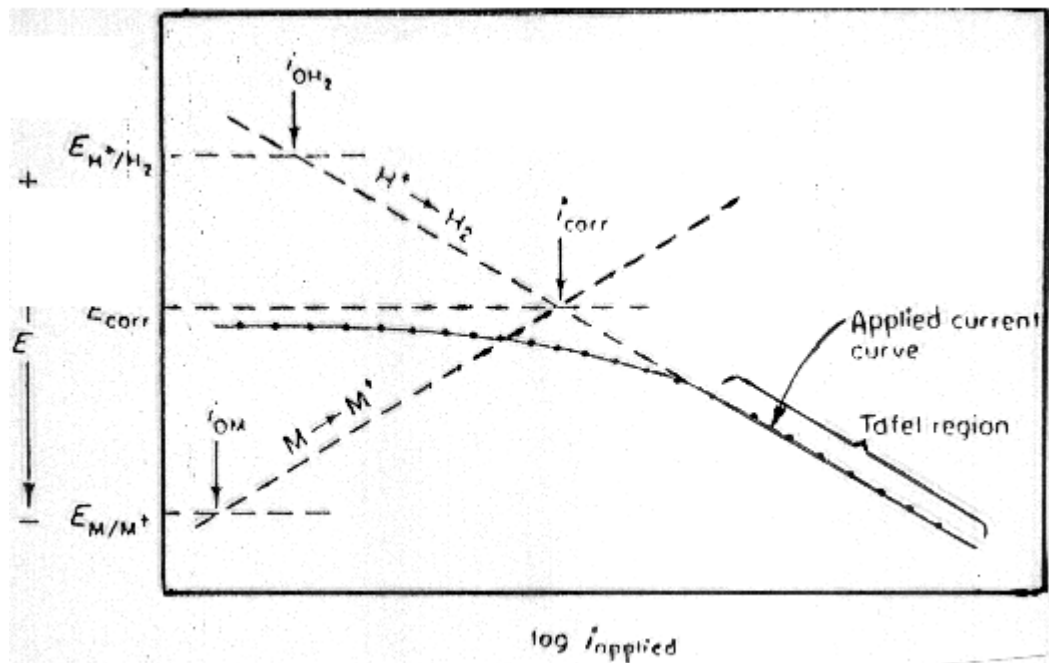

Fig. Tafel Extrapolation Technique on Cathodic Region.

Calculation of corrosion rate from the corrosion current

The corrosion current, usually denoted in A or A/m^2 , can be used to determine the amount of corroded material. The current can be directly converted into the mass of the lost material by using Faraday's law:

$$Q = \frac{nFW}{M}$$

where Q represents charge passed in coulombs, n is the number of electrons involved in the redox reaction, W is the mass of electroactive species (g), and M is molecular weight (g/mol).

$$W = \frac{QM}{nF} \quad W = \frac{Q \times EW}{F} \quad W = \frac{i \times t \times EW}{F} \quad \mathbf{1}$$

where EW represents the equivalent weight of the material, while Q is the product of total current passed in t sec. If Eq. 1 is divided by the density of the electrode material and geometric surface area, A (in cm^2), an expression for the corrosion penetration rate (CPR) is obtained.

$$CPR(\text{cm/s}) = \frac{I_{\text{corr}} \times EW}{dnF}$$

The CPR or W/t is corrosion rate in cm/s and " d " is the density of the material. Other conventional forms of corrosion rate are expressed in Table 5.1.

$$CR(\text{cm/s}) = \frac{I_{\text{corr}} \times EW}{dF}$$

$$CR(\text{mpy}) = \frac{I_{\text{corr}}(\mu\text{A}/\text{cm}^2) \times EW}{d(\text{g}/\text{cm}^3)96,485(\text{C}/\text{eq})1\text{cm}^2 10^6 \mu\text{A}} \frac{1\text{C}/\text{s}}{3600\text{s}} \frac{24\text{h}}{\text{day}} \frac{365\text{days}}{\text{year}} \frac{1\text{in.}}{2.54\text{cm}} \frac{1000\text{mil}}{1\text{in.}}$$

$$CR(\text{mpy}) = \frac{0.129 \times I_{\text{corr}} \times EW}{d} \quad 2$$

In Eq. 2, mpy = mils/year; I_{corr} = corrosion current density ($\mu\text{A}/\text{cm}^2$); EW = equivalent weight of the corroding species, (g/eq); and d = density of the corroding species, (g/cm^3).

Table Relationship Between Various Commonly Used Units of Corrosion Rates and Their Expressions

	mA/cm^2	mm/year	mpy	$\text{g}/(\text{m}^2 \times \text{day})$
mA/cm^2	1	$\frac{3.28M}{nd}$	$\frac{129M}{nd}$	$\frac{8.95M}{n}$
mmpy	$\frac{0.306nd}{M}$	1	39.4	$\frac{2.74d}{n}$
mpy	$\frac{0.00777nd}{M}$	0.0254	1	$\frac{0.0694d}{n}$
$\text{g}/\text{m}^2/\text{day}$	$\frac{0.112n}{M}$	$\frac{0.365}{d}$	$\frac{14.4}{d}$	1

Table Additional Conversion Factors

Multiply	By	To Obtain
ipy	25.4	mmpy
mdd	0.1	gmd
mA/cm^2	10	A/m^2
A/m^2	0.093	A/ft^2
Å	0.1	nm (nanometer)

Example

Tin ($d = 7.3 \text{ g}/\text{cm}^3$) corrodes in a deaerated solution of pH 2.0. The activity of Sn^{2+} in the solution is 10^{-3} M . The value of the cathodic, b_c , and anodic, b_a , Tafel slopes are -0.12 and $+0.1 \text{ V}/\text{decade}$, respectively. The exchange current density for tin and for hydrogen on tin are $i_a^0 = 10^{-6} \text{ A}/\text{cm}^2$ and $i_c^0 = 10^{-8} \text{ A}/\text{cm}^2$, respectively. Assume that the tin surface acts as cathode.

- Calculate the corrosion potential, the corrosion density current in A/cm^2 , and the corrosion rate in grams per square meter per day (gmd) and mils per year (mpy).
- Recalculate the values of the parameters estimated in (a) for pH of 4, 6, and 8, and plot the dependence of the corrosion rate on pH.

Solution:

(a)

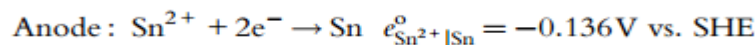

$$e_{\text{Sn}^{2+}|\text{Sn}} = e_{\text{Sn}^{2+}|\text{Sn}}^0 - \frac{0.059}{n} \log \left(\frac{1}{(\text{Sn}^{2+})} \right) = -0.136 - \frac{0.059}{2} \log \left(\frac{1}{10^{-3}} \right) = -0.225 \text{ vs. SHE}$$

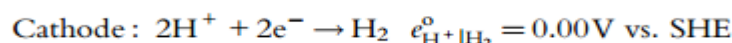

$$e_{\text{H}^+|\text{H}_2} = e_{\text{H}^+|\text{H}_2}^0 - \frac{0.059}{n} \log \left(\frac{1}{(\text{H}^+)^2} \right) = 0.00 - \frac{0.059}{2} \log \left(\frac{1}{(10^{-2})^2} \right) = -0.118 \text{ vs. SHE}$$

$$\eta = E_{\text{corr}} - e_{\text{eq}} = b \times \log \left(\frac{I_{\text{corr}}}{i^{\circ}} \right)$$

$$\eta_a = E_{\text{corr}} - e_a = b_a \log I_{\text{corr}} - b_a \log i_a^{\circ}$$

$$E_{\text{corr}} - (-0.225) = 0.1 \times \log I_{\text{corr}} - 0.1 \times \log (10^{-6}) \quad (\text{A}_1)$$

$$\eta_c = E_{\text{corr}} - e_c = b_c \log I_{\text{corr}} - b_c \log i_c^{\circ}$$

$$E_{\text{corr}} - (-0.118) = -0.12 \times \log I_{\text{corr}} - (-0.12) \times \log (10^{-8}) \quad (\text{B}_1)$$

Solving equations (A₁) and (B₁) simultaneously

$$I_{\text{corr}} = 2.49 \times 10^{-7} \text{ A/cm}^2 = 0.249 \mu\text{A/cm}^2$$

$$E_{\text{corr}} = -0.285 \text{ V}$$

$$\text{CR (mpy)} = \frac{0.131 \times I_{\text{corr}} \times (\text{EW})}{d} = \frac{0.131 \times (0.249) \times \left(\frac{118.710}{2} \right)}{7.30} = 0.265 \text{ mpy}$$

$$\text{CR in (gmd)} = 0.265 \text{ mpy} \times 0.0694 \times d$$

$$\text{CR in (gmd)} = 0.265 \times 0.0694 \times 7.30 = 0.134 \text{ gmd}$$

The corrosion potential, corrosion current density, and the corrosion rates at pH 4, 6, and 8 are calculated using the method described in (a). The results are summarized in Table 1. The plot of corrosion rate vs. pH is shown in Fig. 1.

Table 1. Electrochemical Properties of Sn²⁺/Sn at Different pH

pH	E_a (V)	E_c (V)	E_{corr} (V)	I_{corr} (A/cm ²)	CR (mpy)	CR (gmd)
2	-0.225	-0.118	-0.285	2.49×10^{-07}	0.265	0.134
4	-0.225	-0.236	-0.339	7.23×10^{-08}	0.077	0.039
6	-0.225	-0.354	-0.393	2.1×10^{-08}	0.0224	0.0113
8	-0.225	-0.472	-0.446	6.11×10^{-09}	0.00651	0.0033

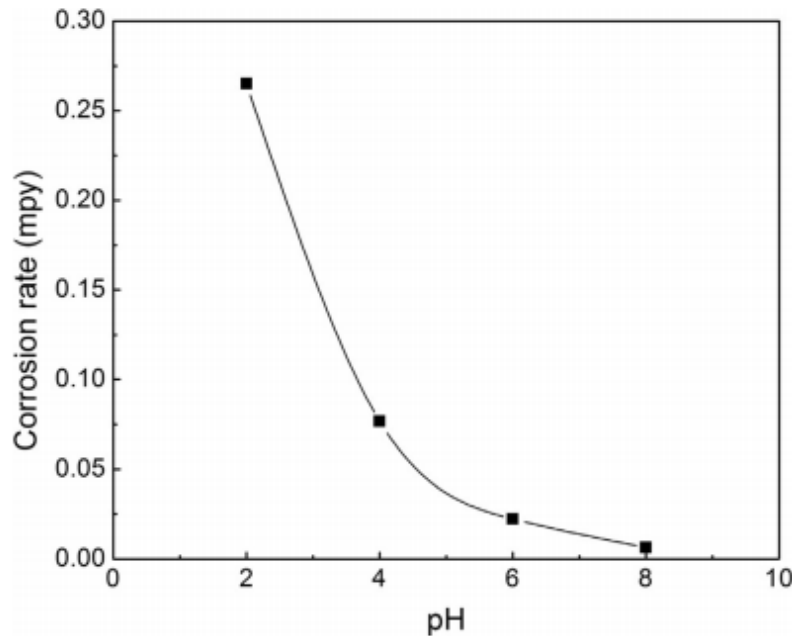
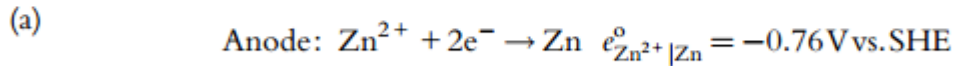

Fig. 1. Corrosion rate in mpy as a function of pH for tin.

Example

The zinc ($d=7.14 \text{ g/cm}^3$) corrosion rate in a deaerated solution of pH 1 is 3785 mpy. Assuming the zinc surface acts as cathode, calculate the corrosion potential of zinc vs. hydrogen reference electrode. The activity of the metal in solution is 10^{-2} M . The value of the anodic Tafel slope, b_a , is 0.1 V per decade. The exchange current density for zinc is 10^{-5} A/cm^2 .

Solution:

$$e_{\text{Zn}^{2+}|\text{Zn}} = e_{\text{Zn}^{2+}|\text{Zn}}^{\circ} - \frac{0.0591}{n} \log \left(\frac{1}{(\text{Zn}^{2+})} \right) = -0.76 - \frac{0.0591}{2} \log \left(\frac{1}{10^{-2}} \right)$$

$$= -0.819 \text{ V vs. SHE}$$

Calculation of the corrosion current:

$$\text{CR}(\text{mpy}) = 3785 = \frac{0.131 \times I_{\text{corr}} \times (\text{EW})}{d} = \frac{0.131 \times I_{\text{corr}} \times (65.4/2)}{7.14}$$

$$\text{Solving for } I_{\text{corr}} \rightarrow I_{\text{corr}} = 6309 \mu\text{A/cm}^2$$

Calculation of corrosion potential:

$$E_{\text{corr}} - (-0.819) = 0.1 \log I_{\text{corr}} - 0.1 \log (10^{-5})$$

$$E_{\text{corr}} = 0.1 \log I_{\text{corr}} - 0.1 \log (10^{-5}) - 0.819$$

$$E_{\text{corr}} = 0.1 \log (6309) - 0.1 \log (10^{-5}) - 0.819 = -0.539 \text{ V vs. SHE}$$

Chapter 4

PASSIVITY

PASSIVITY

A passive metal is one that is active in the Emf Series, but that corrodes nevertheless at a very low rate. Passivity is the property underlying the useful natural corrosion resistance of many structural metals, including aluminum, nickel, and the stainless steels. Some metals and alloys can be made passive by exposure to passivating environments (e.g., iron in chromate or nitrite solutions) or by anodic polarization at sufficiently high current densities (e.g., iron in H_2SO_4). Figure below illustrates the typical behavior of a metal that demonstrate passive effects. The behavior of this metal or alloy can divided into three regions:

1. *Active region*: the behavior of this metal is identical to that of normal metal. Slight increase in oxidizing power (potential) of solution cause rapid increase in corrosion rate.
2. *Passive region*: if the oxidizing agent is added the corrosion rate shows sudden decrease.
3. *Transpassive region*: at very high concentration of oxidizing agent corrosion rate again increased with oxidizer power.

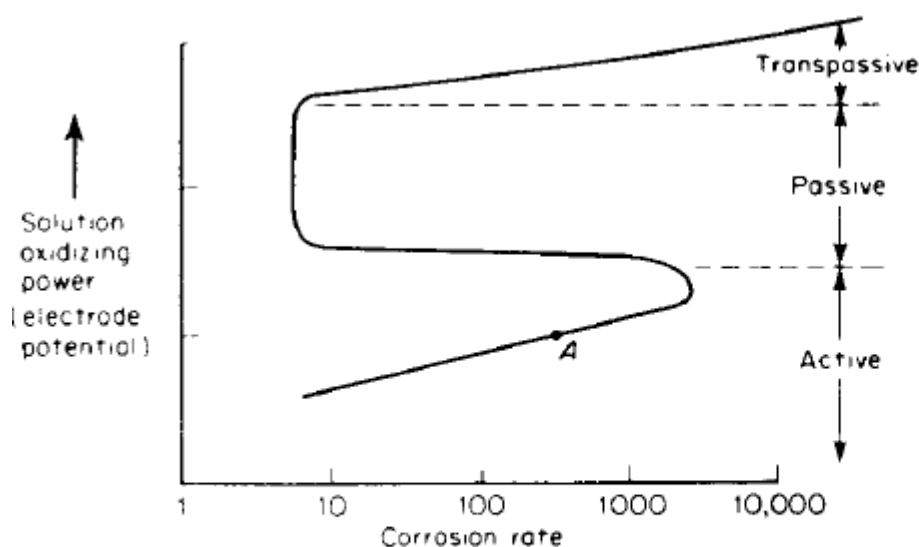

Figure Corrosion characteristics of an active-passive metal as a function of solution oxidizing power (electrode potential).

CHARACTERISTICS OF PASSIVATION

Theoretical anodic polarization curves of passivated metals

1. Four regions of the anodic polarization curve of passivated metal

(1) A-B section — active region

Metal is in anodic dissolution state. Polarization curve follows Tafel equation with the increase of potential.

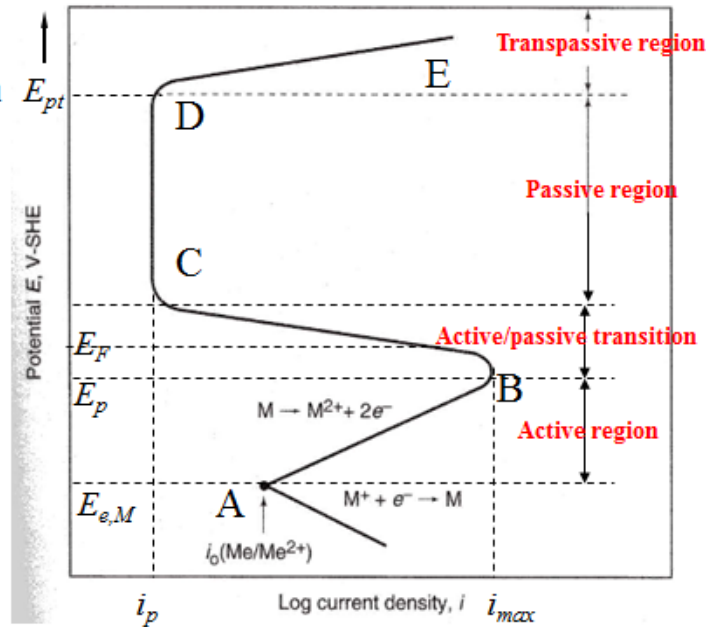
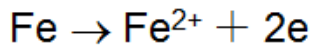

Anodic polarization curve of passivated metal

(2) B-C section — Active/passive transition

When the electrode potential increases to a critical value E_p , the passive film is formed on metal surface. The current density drops precipitously

E_p \Rightarrow passive potential

i_{max} \Rightarrow critical current density

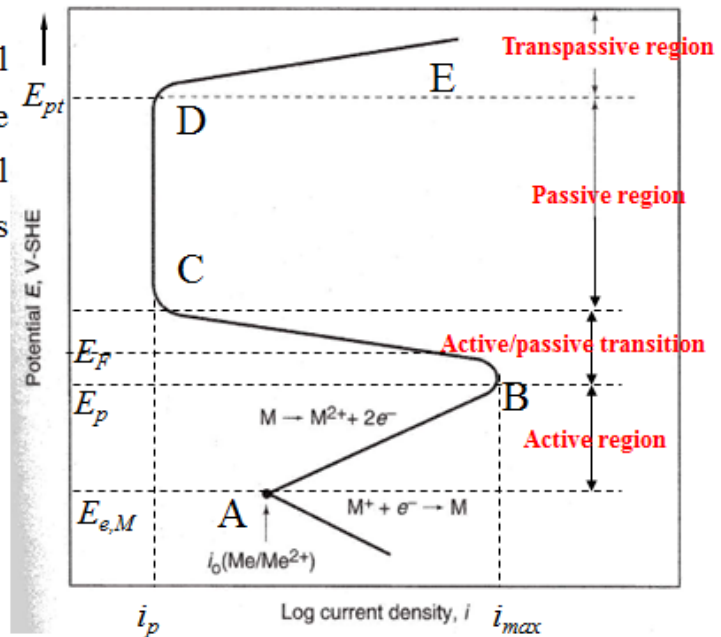
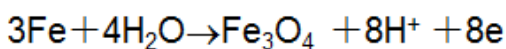

Anodic polarization curve of passivated metal

(3)C-D section — passive region

The metal is in steady passivation state. Passive film is formed on metal surface. The current density is almost independent of the potential.

$i_p \Rightarrow$ passive current density

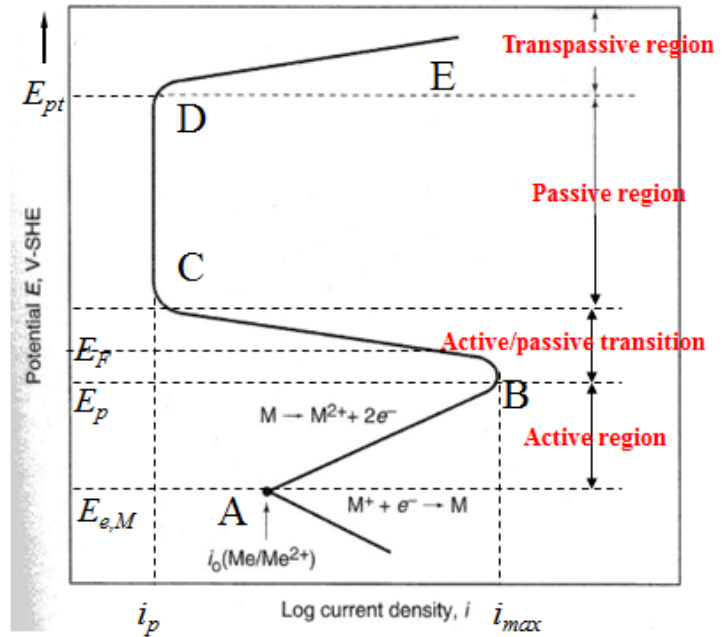
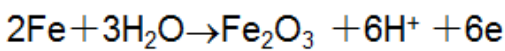

Anodic polarization curve of passivated metal

(4)D-E section — transpassive region

When the potential is further increased, the current density increases. The passive film is damaged.

$E_{pt} \Rightarrow$ transpassive potential

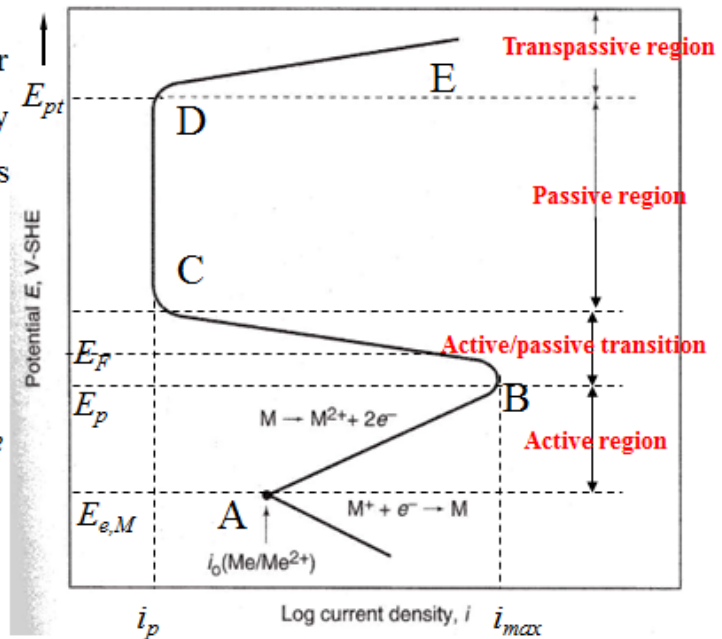
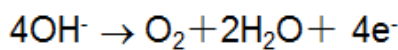
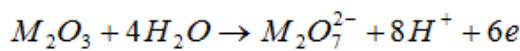

Anodic polarization curve of passivated metal

Two characteristics of metal passivity

- Considerable drop of corrosion rate (current density)
- Positive shift of potential prominently

FLADE POTENTIAL, E_F

The most negative potential at which this state is attained is called the *Flade potential*, E_F . This represents the most negative limit of stability of the passive state, and is usually determined by allowing the potential to become more negative from the passive state, so that the transition to the active state is observed.

$$E_F(\text{volts, S.H.E.}) = +0.63 - 0.059\text{pH}$$

EXAMPLES OF PASSIVITY

Aluminum in water: Consider the reaction of aluminum with water, as in conditions of immersion or exposure in the atmosphere:



The free energy G° of the reaction can be determined from the thermodynamic principles:

$$G^\circ = 2(-376,000 \text{ cal}) + 12(-37,595 \text{ cal}) - 12(-56,690 \text{ cal}) = -522,860 \text{ cal}$$

This large negative value of the free energy change for Eq. (1) indicates that the reaction of aluminum with water is spontaneous.

- Thus, the surface of aluminum reacts with water to form an oxide film.
- However, the reaction essentially stops after the aluminum surface is covered with an oxide film, which may be only hundreds to thousands of angstroms in thickness.
- The reaction stops because the aluminum metal has formed a **passive oxide film** that protects the underlying metal from further attack.

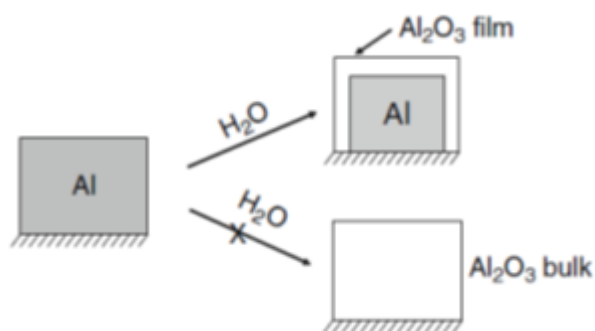

For Fe in the nitric acid solution:

- $w < 30\%$: the corrosion rate increases with increasing w . The potential of steel is low.
- $w > 30\%$: the corrosion rate decreases with increasing w . The potential of steel shifts positively — Passivity
- $w = 80\%$: the corrosion rate increases with increasing w — Transpassivity

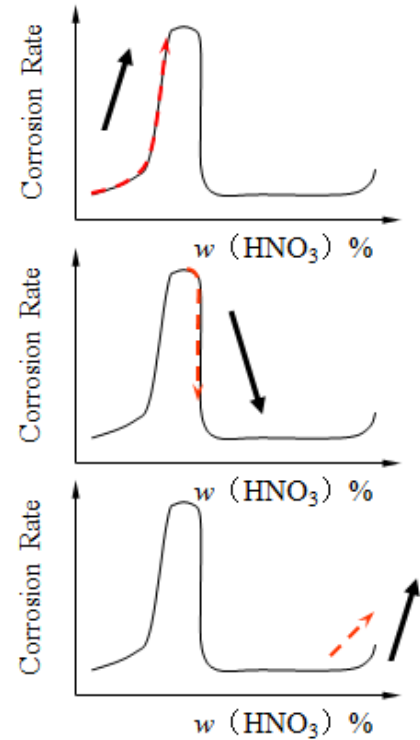

CLASSIFICATION OF PASSIVITY

{	Chemical passivity	Passivity is caused by the reaction between metal and passivation agent
	Electrochemical passivity	Passivity is caused by applying anodic current density (or positive shift of potential)

THEORIES OF PASSIVATION

Major theories that have been proposed are:

- Oxide film theory.
- Adsorption theory

The oxide theory attributes corrosion resistance of passive metals and alloys to the formation of a protective film on the metal surface; the film can be as a monolayer. A stable passive film is

free from porosity and presents a protective barrier between the metal and the corrosive environment.

The adsorption theory is based on chemisorbed films. Oxygen adsorption on surfaces can reduce corrosion activity. Adsorbed oxygen atoms significantly decrease the exchange current density, thus increasing anodic polarization, favorable for passivation.

KINETICS OF PASSIVATION

Assume a defect-free single crystal and a mechanism of oxide film growth by vacancy migration. Thus, the rate of film formation for a single crystal, related to Faraday's law, can be approximated as

$$\frac{dx}{dt} = \frac{iM}{zF\rho}$$

Where, x = film thickness (cm), $\frac{dx}{dt}$ = rate of film formation (cm/s), i_p = passive current density (A/cm^2), z = valence, $F = 96,500 C/mol (= A.s/mol)$, ρ = density of metal (g/cm^3).

Chapter 5

EFFECT OF ENVIRONMENTAL PARAMETERS ON CORROSION

EFFECT OF TEMPERATURE:

Temperature increases the rate of almost all-chemical reactions. An increase in temperature of a corroding system has four main effects:

1. The rate of chemical reaction is increased.
2. The solubility of gases in solution is decreased.
3. The solubility of some of the reaction products may change, resulting in a different corrosion reaction products; and
4. Viscosity is decreased, and many thermal differences will results in increased circulation.

When corrosion is controlled by diffusion of oxygen, the corrosion rate at a given oxygen concentration approximately doubles for every 30 °C rise in temperature. When corrosion is attended by hydrogen evolution, the rate increasing is more than double for every 30°C rise in temperature. Arrhenius type equation:

$$\text{Corrosion Rate (C.R.)} = A \text{ Exp} \left(-\frac{E}{RT} \right)$$

Where: A = Modified Frequency factor (pre-exponential factor), E = Activation energy (J/mole), R = Gas constant (8.314 J/mole.K), T = Absolute temperature (K).

Example:

Following data for the corrosion rate (g/m²day) of mild steel in HCl, estimate the values of Modified Frequency factor (pre-exponential factor) and E, Activation energy (J/mole).

HCl conc. M	Temperature °C			
	30	40	50	60
1	39.35	153.82	279.81	456.17
3	75.85	177.82	741.31	1905.46
5	602.55	1318.25	2454.71	3990.249

Solution:

The linear form of Arrhenius type equation is:

$$\ln (C.R.) = \ln A - \frac{E}{R T} \quad \text{That can be drawn as } \ln (C.R.) \text{ vs } 1/T.$$

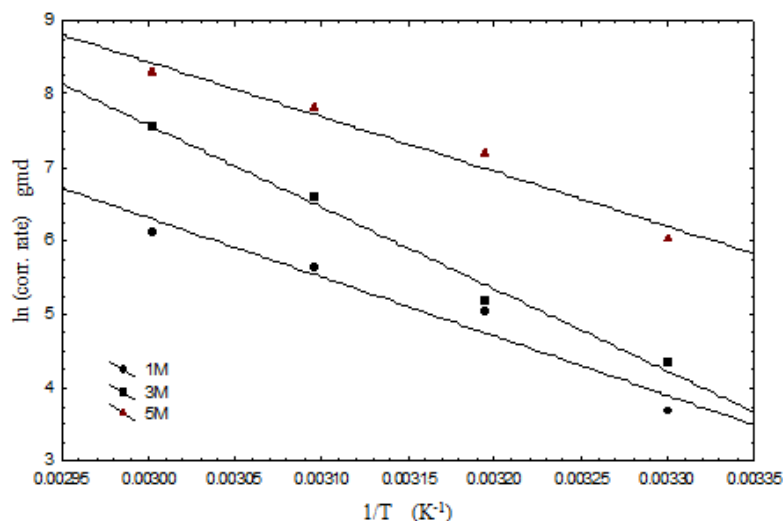

Arrhenius Plot for the Corrosion of Low Carbon Steel in HCl Acid

Conc. M	E (kJ/mol)	A (day ⁻¹)
1	70.12	45.7×10 ¹²
3	56.36	16.5×10 ¹²
5	52.94	8.4×10 ¹²

EFFECT OF DISSOLVED OXYGEN AND OXIDIZERS

Dissolved oxygen is the main cause of corrosion in neutral aqueous solutions because it represents the main cathodic reaction that occurs on cathodic areas. Corrosion in acids is also accelerated by the presence of oxygen. Corrosion takes place by both oxygen depolarization and hydrogen gas evolution. Thus in the presence of oxygen corrosion in acids may be over ten times as higher as in the absence of oxygen. The relation between dissolved oxygen and pH is shown in Fig. below. It shows that there is little effect of **hydrogen ions between pH values of 5-10**, and that the corrosion rate depends only on how rapidly oxygen diffuses to the metal surface. Within the acid region (**pH < 4**), the oxide films are dissolved; the surface pH falls and metal is less direct contact with the aqueous environment. The increased rate reaction is then the sum of both appreciable rate of hydrogen evolution and oxygen depolarization. **Above pH of 10**, increase in alkalinity of the environment raises the pH of the iron surface. The corrosion rates correspondingly decrease because iron becomes increasingly passive in presence of alkalis and dissolved oxygen.

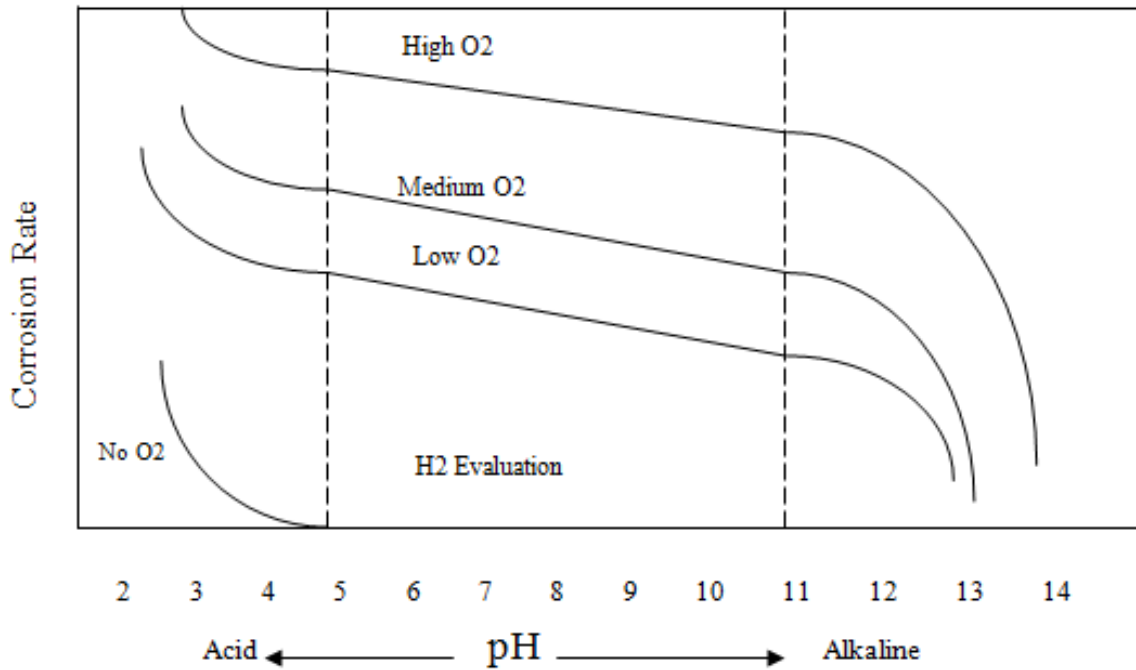

Fig. Corrosion Rate as a Function of pH and Dissolved Oxygen.

EFFECT OF VELOCITY

The effects of velocity on corrosion rate are like the effect of oxidizer addition, complex and depend on the characteristics of the metal and environment to which it is exposed. Increased the velocity may increase or reduce attack, depend on its effect on the corrosion mechanism involved. It may increase attack on metal by increasing the supply of oxygen in contact with the metal surface, or velocity may increase the diffusion or transfer of ions by reducing the thickness of the stagnant film at the surface. At the other end, a fast moving fluid generates turbulence that provides enhanced mass transfer. The mass transfer coefficient can be expressed in terms of the dimensionless Reynolds (Re), Schmidt (Sc) and Sherwood (Sh) numbers. These numbers are defined by:

$$Re = \frac{\rho u d_{\epsilon}}{\mu} \quad Sc = \frac{\mu}{\rho D} \quad Sh = \frac{k_a d}{D} \quad \mathbf{a}$$

Where ρ is the density, u is the linear velocity, d is the inner tube diameter, μ is the dynamic viscosity, D is the diffusivity of oxygen in seawater, and k_d is the mass transfer coefficient. For single phase flow in a straight pipe, the correlation of Anederko can be used:

$$Sh = 0.0165 Re^{0.86} Sc^{0.33}$$

Example

Find the mass transfer coefficient as a function of Reynolds number. For flow of saline water in steel tube. The physical properties of seawater at 25° C and pH=7 are: $\rho = 1.0311 \text{ g/cm}^3$, $\mu = 0.962 \times 10^{-3} \text{ kg/m.s}$, $D = 1.9 \times 10^{-5} \text{ cm}^2/\text{s}$. solving of equations a yield the values of k_d . Figure below shows the variation of mass transfer coefficient, k_d , with Re . It can be seen that the k_d increases with increasing Re , that means the corrosion rate increases with increasing Re .

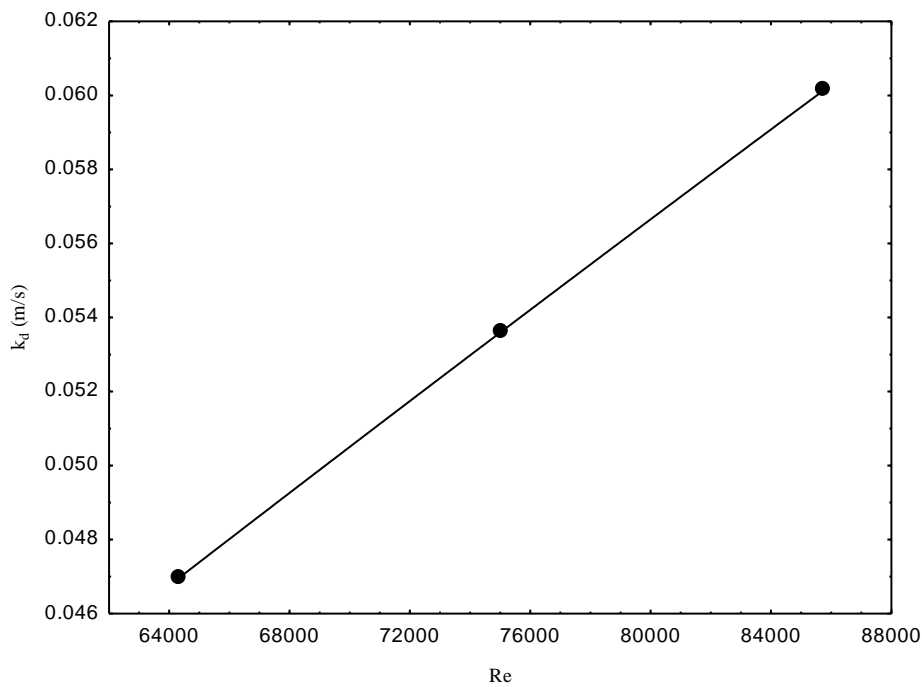
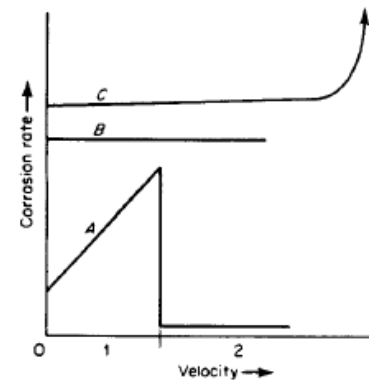

Fig. Effect of Reynold number on mass transfer coefficient for flow of 3.5% NaCl solution in mild steel pipe at 4% sand, and 4 h.

Figure shows typical observations when agitation or solution velocity are increased. For corrosion processes that are controlled by activation polarization, agitation and velocity have no effect on the corrosion rate as illustrated in curve *B*. If the corrosion process is under cathodic diffusion control, then agitation increases the corrosion rate as shown in curve *A*, section 1. This effect generally occurs when an oxidizer is present in very small amounts, as is the case for dissolved oxygen in acids or water.

If the process is under diffusion control and the metal is readily passivated, then the behavior corresponding to curve *A*, sections 1 and 2, will be observed. That is, with increasing agitation, the metal will undergo an active-to-passive transition. Easily passivated materials such as stainless steel and titanium frequently are more corrosion resistant when the velocity of the corrosion medium is high.

Some metals owe their corrosion resistance in certain mediums to the formation of massive bulk protective films on their surfaces. These films differ from the usual passivating films in that they are readily visible and much less tenacious. It is believed that both lead and steel are protected from attack in sulfuric acid by insoluble sulfate films. When materials such as these are exposed to extremely high corrosive velocities, mechanical damage or removal of these films can occur, resulting in accelerated attack as shown in curve *C*. This is called erosion corrosion



Examples

Curve A :

- 1 : Fe in $H_2O + O_2$
Cu in $H_2O + O_2$
1-2 : 18Cr-8Ni in $H_2SO_4 + Fe^{+3}$
Ti in HCl + Cu^{+2}

Curve B :

- Fe in dilute HCl
18Cr-8Ni in H_2SO_4

Curve C :

- Pb in dilute H_2SO_4
Fe in concentrated H_2SO_4

EFFECT OF ACID CONCENTRATION

Normally as the concentration of a corrosive acid media is increased, the corrosion rate is likewise increased. This is primarily due to the fact that the amounts of hydrogen ions, which are the active species, are increased, as acid concentration is increased. Hydrogen ion activity is commonly expressed, for convenience in term of pH. At low pH values hydrogen evolution usually predominate both in presence and absence of oxygen. Another behavior can be observed.

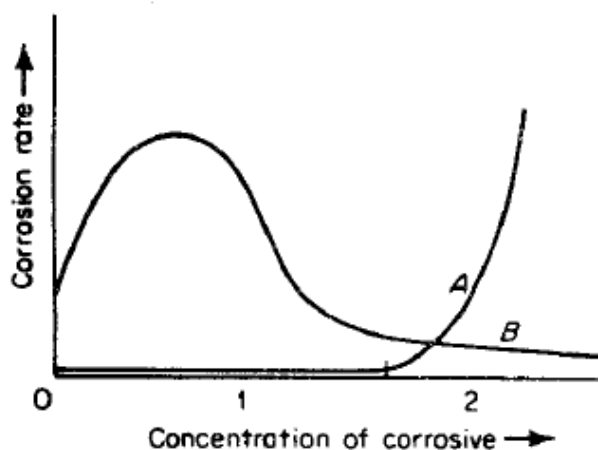

Examples

Curve A :

- 1 : Ni in NaOH
18Cr-8Ni in HNO_3
Hastelloy B in HCl
Ta in HCl
1-2 : Monel in HCl
Pb in H_2SO_4

Curve B :

- Al in acetic acid and HNO_3
18Cr-8Ni in H_2SO_4
Fe in H_2SO_4

Figure shows schematically the effects of corrosive concentration on corrosion rate. Note that curve *A* has two sections, 1 and 2. Many materials that exhibit passivity effects are only negligibly affected by wide changes in corrosive concentration, as shown in curve *A*, section 1. Other materials show similar behavior except at very high corrosive concentrations, when the corrosion rate increases rapidly as shown in curve *A*, sections 1 and 2. Lead is a material that shows this effect, and it is believed to be due to the fact that lead sulfate, which forms a protective film in low concentrations of sulfuric acid, is soluble in concentrated sulfuric acid. The behavior of acids that are soluble in all concentrations of water often yield curves similar to curve *B* in Fig. . Initially, as the concentration of corrosive is increased, the corrosion rate is likewise increased. This is primarily due to the fact that the amount of hydrogen ions, which are the active species, are increased as acid concentration is increased. However, as acid concentration is increased further, corrosion rate reaches a maximum and then decreases. This is undoubtedly due to the fact that at very high concentrations of acids ionization is reduced. Because of this, many of the common acids—such as sulfuric, acetic, hydrofluoric, and others—are virtually inert when in the pure state, or 100% concentration, and at moderate temperatures.

Chapter 6

Some Applications of Electrochemistry

1. Fuel Cell

What is a fuel cell?

- A fuel cell is like a battery in that it generates electricity from an electrochemical reaction.
- Both batteries and fuel cells convert chemical energy into electrical energy and also, as a by-product of this process, into heat.
- However, a battery holds a closed store of energy within it and once this is depleted the battery must be discarded, or recharged by using an external supply of electricity to drive the electrochemical reaction in the reverse direction.
- A fuel cell, on the other hand, uses an external supply of chemical energy and can run indefinitely, as long as it is supplied with a source of hydrogen and a source of oxygen (usually air).
- The source of hydrogen is generally referred to as the fuel and this gives the fuel cell its name, although there is no combustion involved.
- Oxidation of the hydrogen instead takes place electrochemically in a very efficient way.
- During oxidation, hydrogen atoms react with oxygen atoms to form water; in the process electrons are released and flow through an external circuit as an electric current.
- Fuel cells can vary from tiny devices producing only a few watts of electricity, right up to large power plants producing megawatts.
- All fuel cells are based around a central design using two electrodes separated by a solid or liquid electrolyte that carries electrically charged particles between them.

- A catalyst is often used to speed up the reactions at the electrodes.
- Fuel cell types are generally classified according to the nature of the electrolyte they use.
- Each type requires particular materials and fuels and is suitable for different applications.

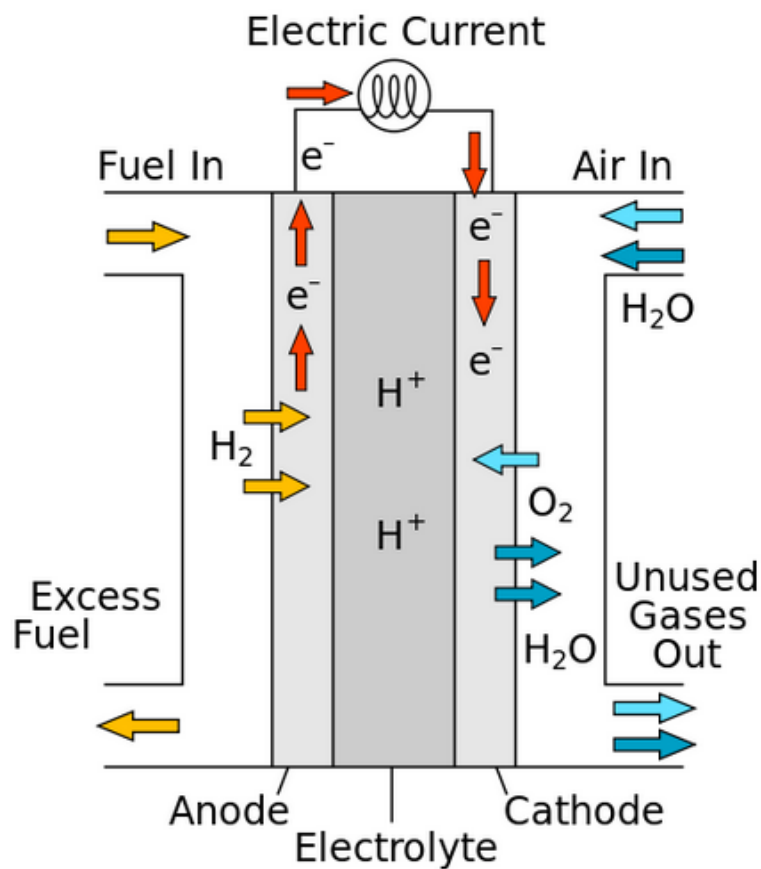
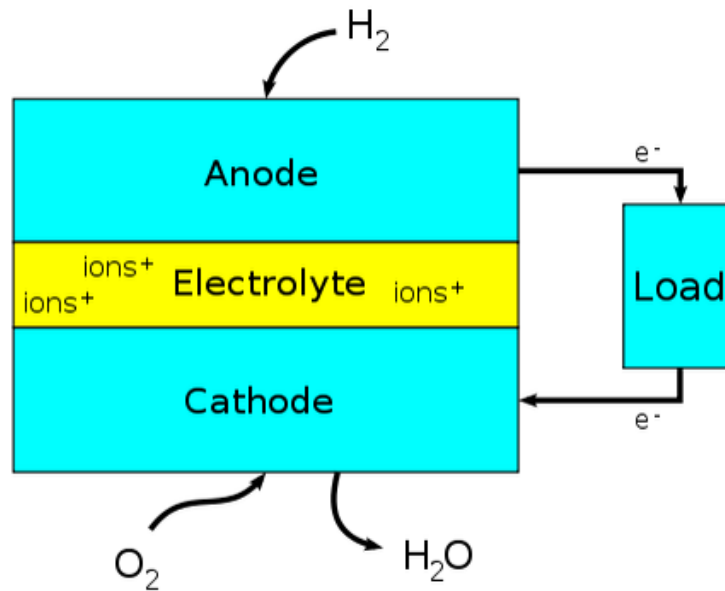

Scheme of a proton-conducting fuel cell

Types of Fuel Cell

PEMFC – Proton Exchange Membrane Fuel Cells

- Electrolyte: water-based, acidic polymer membrane
- Also called polymer electrolyte membrane fuel cells
- Use a platinum-based catalyst on both electrodes
- Generally hydrogen fuelled
- Operate at relatively low temperatures (below 100°C)
- High-temperature variants use a mineral acid-based electrolyte and can operate up to 200°C.
- Electrical output can be varied, ideal for vehicles

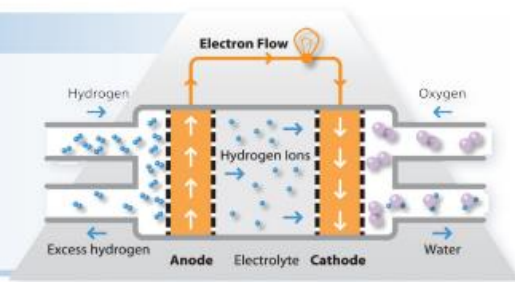

Direct Methanol Fuel Cells – DMFC

- Electrolyte: polymer membrane (like PEMFC)
- Use a platinum–ruthenium catalyst on the anode and a platinum catalyst on the cathode
- This catalyst can draw hydrogen atoms from liquid methanol, which is used as fuel instead of hydrogen, giving the cell its name.
- Operate in the range from 60°C to 130°C
- DMFC are convenient for portable power applications with outputs generally less than 250 W

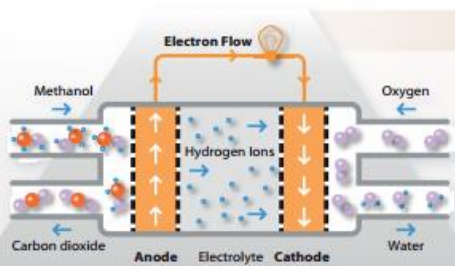

PAFC – Phosphoric Acid Fuel Cells

- Electrolyte: liquid phosphoric acid in a bonded silicon carbide matrix
- Use a finely dispersed platinum catalyst on carbon
- Quite resistant to poisoning by carbon monoxide
- Operate at around 180°C
- Electrical efficiency is relatively low, but overall efficiency can be over 80% if the heat is used
- Used in stationary power generators (100 kW to 400 kW)

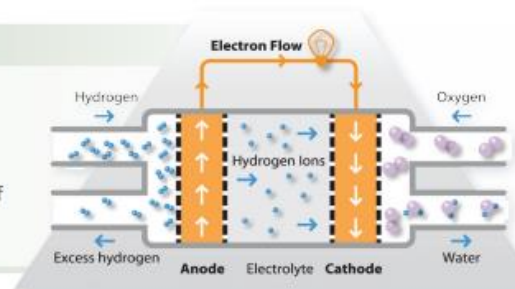

Alkaline Fuel Cells – AFC

- Electrolyte: alkaline solution such as potassium hydroxide in water
- Commonly use a nickel catalyst
- Generally fuelled with pure hydrogen and oxygen as they are very sensitive to poisoning
- Typical operating temperatures are around 70°C
- Can offer high electrical efficiencies
- Tend to have relatively large footprints
- Used on NASA shuttles throughout the space programme

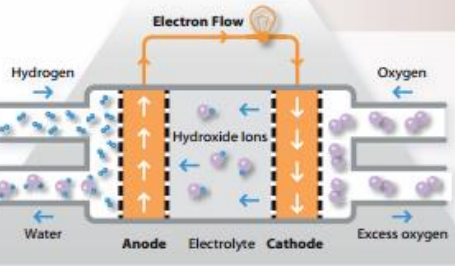

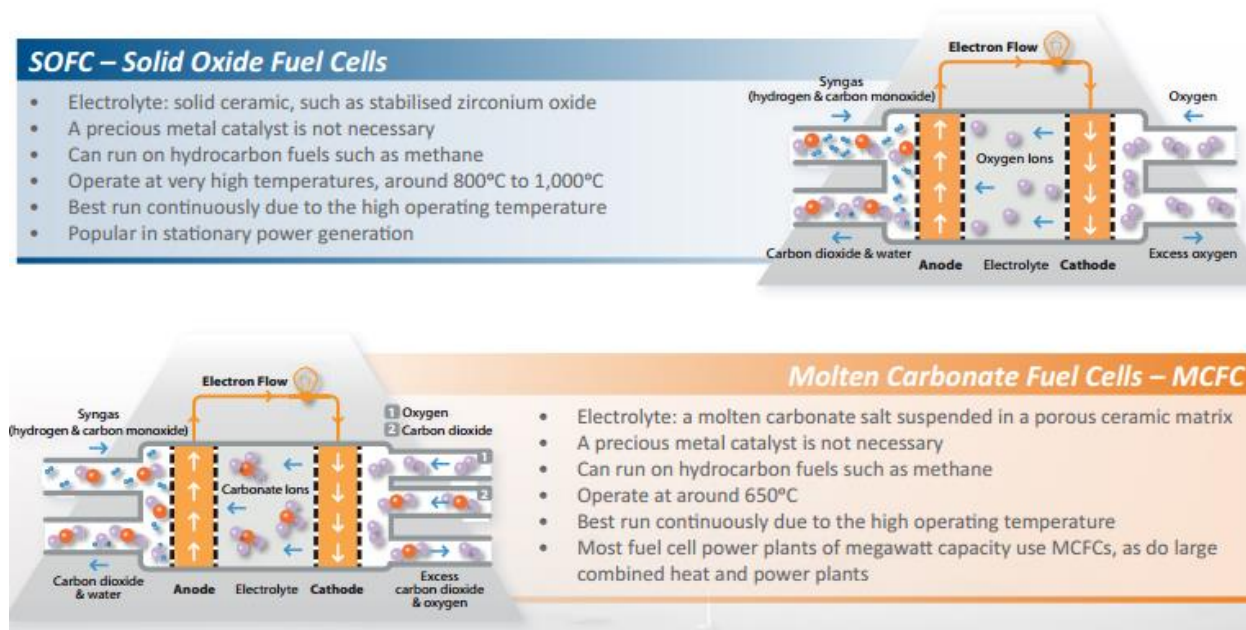

The Electrode Mechanism of Fuel Cells

The electrode reactions of a hydrogen - oxygen fuel cell in acid or alkaline electrolyte, and the overall reactions, are as follows:

In acid electrolyte

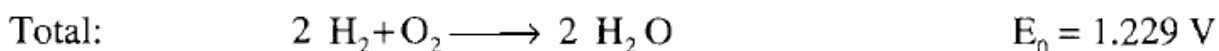
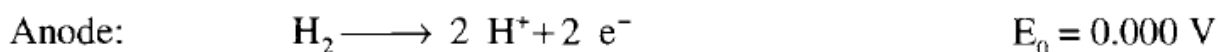

In alkaline electrolyte

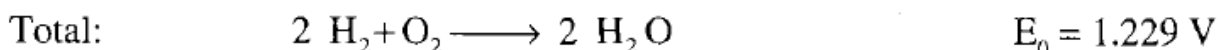
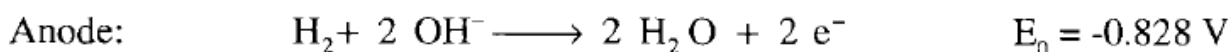
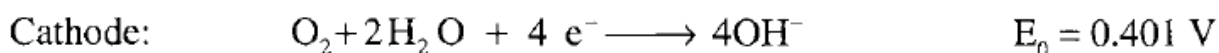

The basic electrochemical cell consists of two electrodes separated by an electrolyte. The energy conversion reactions occur at the electrodes, with fuel oxidation at the anode and oxidant reduction

at the cathode. The hydrogen oxygen fuel cell with alkaline electrolyte is schematically shown in Figure below.

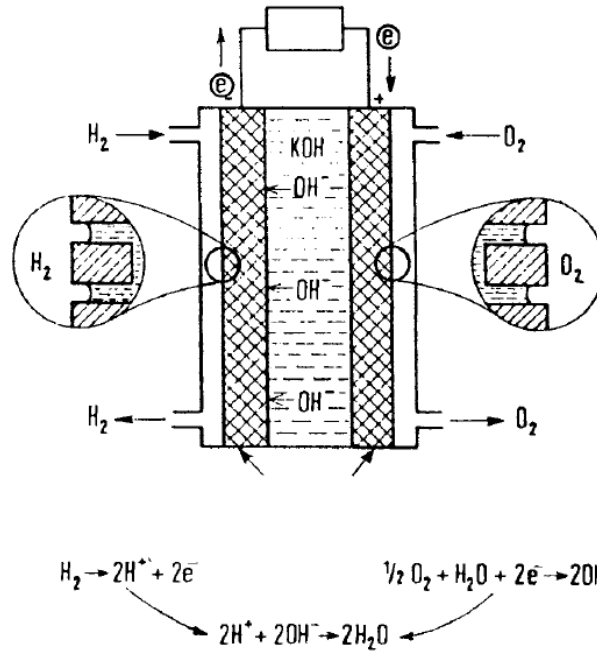

The cell potential is estimated using equation:

$$E_{\text{H}_2, \text{O}_2 | \text{H}_2\text{O}} = E_{\text{H}_2, \text{O}_2 | \text{H}_2\text{O}}^\circ + 2.303 \frac{RT}{4F} \log \left(P_{\text{H}_2} (P_{\text{O}_2})^{\frac{1}{2}} \right)$$

This equation was derived considering the partial electrode reaction of hydrogen oxidation and oxygen reduction,

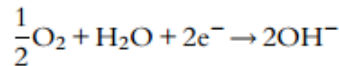
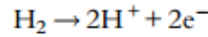

The overall reaction is:

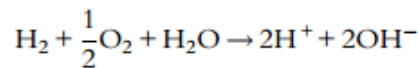

According to the Nernst equation:

$$E_{\text{cell}} = E_{\text{cell}}^\circ + 2.303 \frac{RT}{4F} \log \left(\frac{P_{\text{H}_2} (P_{\text{O}_2})^{1/2} a_{\text{H}_2\text{O}}}{(a_{\text{H}^+})^2 (a_{\text{OH}^-})^2} \right)$$

$$a_{\text{H}^+} a_{\text{OH}^-} = K_w$$

$$E_{\text{cell}} = E_{\text{cell}}^\circ - 2.303 \frac{RT}{F} \log(K_w) + 2.303 \frac{RT}{2F} \log \left(P_{\text{H}_2} (P_{\text{O}_2})^{1/2} \right)$$

$$E_{\text{cell}} = e_{\text{H}^+ | \text{H}_2}^\circ + e_{\text{OH}^- | \text{O}_2}^\circ - 2.303 \frac{RT}{F} \log(K_w) = 0.00 + 0.401 - 0.059 \log(10^{-14})$$

$$E_{\text{cell}} = 0.00 + 0.41 + 0.83 = 1.23 \text{ V}$$

$$E_{\text{cell}} = 1.23 + \frac{0.059}{2} \log \left(P_{\text{H}_2} (P_{\text{O}_2})^{1/2} \right)$$

Example Fuel Flow Rate for 1 Ampere of Current

What hydrogen flow rate is required to generate 1.0 ampere of current in a fuel cell?

Solution:

For every molecule of hydrogen (H₂) that reacts within a fuel cell, two electrons are liberated at the fuel cell anode.

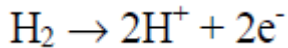

The moles of hydrogen liberated to generate one amp can be calculated directly:

$$n_{\text{H}_2} = (1.0 \text{ A}) \left(\frac{1 \text{ coulomb/sec}}{1 \text{ A}} \right) \left(\frac{1 \text{ equivalence of e}^-}{96,487 \text{ coulombs}} \right) \left(\frac{1 \text{ g mol H}_2}{2 \text{ equiv. of e}^-} \right) \left(\frac{3600 \text{ sec}}{1 \text{ hr}} \right) = 0.018655 \frac{\text{g mol}}{\text{hr} \cdot \text{A}} \text{H}_2$$

$$m_{\text{H}_2} = \left(0.018655 \frac{\text{g mol}}{\text{hr} \cdot \text{A}} \text{H}_2 \right) \left(\frac{2.0158 \text{ g}}{1 \text{ g mol H}_2} \right) \left(\frac{1 \text{ kg}}{1000 \text{ g}} \right) = 37.605 \times 10^{-6} \frac{\text{kg H}_2}{\text{hr} \cdot \text{A}} \text{ or } 0.037605 \frac{\text{kg H}_2}{\text{hr} \cdot \text{kA}}$$

The result of this calculation, 0.037605 kg H₂ per hour per kA (0.08291 lb H₂ per hour per kA), is a convenient factor that is often used to determine how much fuel must be provided to supply a desired fuel cell power output, as illustrated in the next example.

Example Required Fuel Flow Rate for 1 MW Fuel Cell

A 1.0 MWDC fuel cell is operated with a cell voltage of 700 mV on pure hydrogen with a fuel utilization, How much hydrogen will be consumed in lb/hr?

Solution:

Recalling that power (P) is the product of voltage (V) and current (I),

$$P = I \times V$$

Therefore, the current through the fuel cell stack can be calculated as

$$I = \frac{P}{V} = \left(\frac{1.0 \text{ MW}}{0.7 \text{ V}} \right) \left(\frac{10^6 \text{ W}}{1 \text{ MW}} \right) \left(\frac{1 \text{ VA}}{1 \text{ W}} \right) \left(\frac{1 \text{ kA}}{1000 \text{ A}} \right) = 1429 \text{ kA}$$

The quantity of hydrogen consumed within the fuel cell stack is

$$m_{\text{H}_2, \text{consumed}} = (1429 \text{ kA}) \left(\frac{0.08291 \text{ lb H}_2}{\text{hr} \cdot \text{kA}} \right) = 118.4 \frac{\text{lb H}_2}{\text{hr}}$$

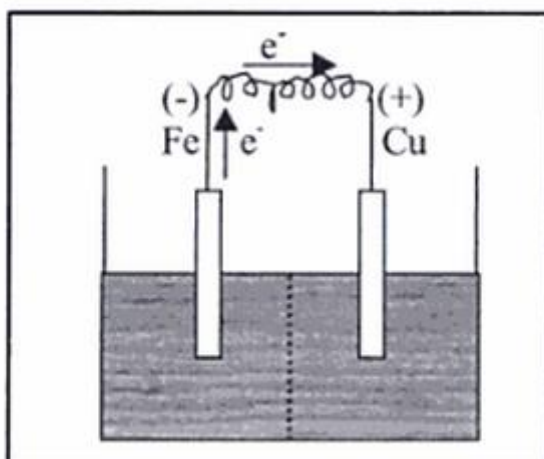
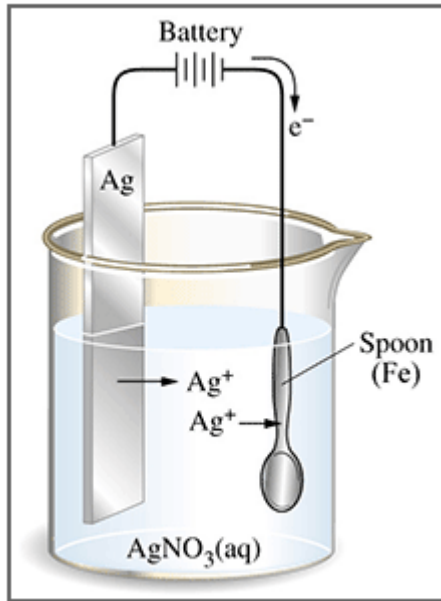

Figure I-11 A galvanic power source

2. Electroplating

- **Electroplating** is a process that uses electric current to reduce dissolved metal cations so that they form a coherent metal coating on an electrode.
- The term is also used for electrical oxidation of anions onto a solid substrate.
- The process used in electroplating is called **electrodeposition**. It is analogous to a galvanic cell acting in reverse.
- The part to be plated is the cathode of the circuit. In one technique, the anode is made of the metal to be plated on the part.
- Both components are immersed in a solution called an electrolyte containing one or more dissolved metal salts as well as other ions that permit the flow of electricity.
- A power supply supplies a direct current to the anode, oxidizing the metal atoms that it comprises and allowing them to dissolve in the solution.
- At the cathode, the dissolved metal ions in the electrolyte solution are reduced at the interface between the solution and the cathode, such that they "plate out" onto the cathode.
- The rate at which the anode is dissolved is equal to the rate at which the cathode is plated.



Silver electroplating. The anode is a silver bar and the cathode is an iron spoon.

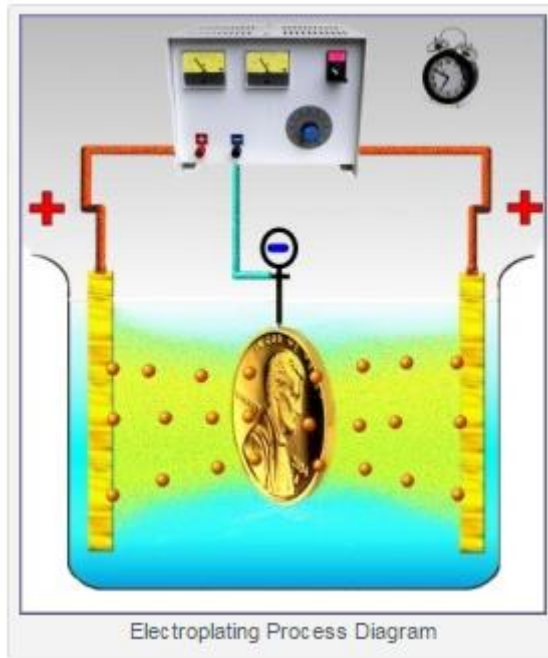

Chapter 7

Corrosion Prevention and Control

Four primary techniques are used for limiting corrosion rates to practical levels:

1. Material Selection
2. Coatings
3. Cathodic Protection
4. Chemical Corrosion Inhibitors









1. Material selection

- entails picking an engineering material – either metal alloy or non-metal – that is inherently resistant to the particular corrosive environment and also meets other criteria.
- Variables that will affect corrosion are established along with materials that may provide suitable resistance for those conditions.
- Obviously other requirements such as cost and mechanical properties of the potential materials must be considered.
- Data needed to thoroughly define the corrosive environment include many of its chemical and physical characteristics plus application variables such as its velocity (or is it ever stagnant?) and possible extremes caused by upset conditions.
- Corrosion tables may be helpful tools for material selection in different environments. These tables are available in handbooks and internet.

Sulphuric acid

H₂SO₄

H ₂ SO ₄ conc % ▶	0.1%	0.5%	0.5%	0.5%	1%	1%	1%	1%	1%	2%	2%	2%	3%	3%	3%	3%	3%	5%
Temp °C	100=BP	20	50	100=BP	20	50	70	85	100=BP	20	50	60	20	35	50	85	100=BP	20
Carbon steel	×	×	×	×	×	×	×	×	×	×	×	×	×	×	×	×	×	×
Moda 410S/4000	×	×	×	×	×	×	×	×	×	×	×	×	×	×	×	×	×	×
Moda 430/4016	×	●	×	×	×	×	×	×	×	×	×	×	×	×	×	×	×	×
Core 304L/4307	×	○	●	×	○	●	●	×	×	○	●	●	○	●	●	×	×	●
Supra 444/4521	×	○	×	×	○	×	×	×	×	○	×	×	○	×	×	×	×	×

	The material is corrosion resistant. Corrosion rate less than 0.1 mm/year.		Risk (Severe risk) of pitting and crevice corrosion.
	The material is not corrosion resistant, but useful in certain cases. Corrosion rate 0.1 - 1.0 mm/year.		Risk (severe risk) of stress corrosion cracking.
	Serious corrosion. The material is not usable. Corrosion rate over 1.0 mm/year.		Risk (severe risk) of crevice corrosion. Used when there is a risk of localised corrosion only if crevices are present. Under more severe conditions, when there is also a risk of pitting corrosion, the symbols p or P are used instead.
	Boiling point of the solution.		Risk of intergranular corrosion.

2. Coatings

- Are the most widely used method for controlling corrosion.
- The possibilities cover a wide range and include such things as paints of many types, electroplating, weld overlays and bonding a thin, corrosion-resistant metal or non-metal onto a stronger substrate metal that is susceptible to corrosion.
- In many cases the coating simply acts as a barrier between the corrosive environment and the substrate material. In some cases such as in galvanized steel the coating (zinc in this case) provides a barrier but it also acts as a sacrificial anodic material to protect the steel below by preferentially corroding instead of the steel. This effect is cathodic protection.
- The coating selection, surface preparation, application and proper quality control throughout the process to attain an optimal coating for the given application requires special experience.

3. Cathodic protection

- Cathodic protection is a corrosion control technology with a long history. It functions due to a fundamental characteristic of corrosion, i.e., when the electrochemical process of corrosion occurs there is a flow of DC electric current from the surface being attacked.
- Cathodic protection (often known as CP) provides a flow of DC current onto the protected surface to counteract corrosion current flow. The resulting rate of corrosion is greatly reduced to allow practical, long-term use of the protected metal, e.g., for 10 to 20 years or more, although corrosion is not stopped. The amount of current necessary to be

supplied to the surface to control the rate to practical levels depends on the area exposed. Thus CP is most often used in conjunction with some type of coating. This greatly lowers the current needed for protection. No coating is 100% free of small areas where the substrate is exposed. Using CP with a coating means current is only needed at these bare spots.

- There are two types of CP. One is the *sacrificial anode* (also called galvanic) type in which a metal more susceptible to corrosion in the given electrolyte is electrically connected to a less susceptible metal to be protected. The former metal becomes the anode and is consumed over time while the latter metal becomes the cathode in a galvanic corrosion cell. Thus the zinc on galvanized steel is the anode while the steel substrate – as the cathode – is protected.
- The second type of CP is *impressed current CP*. Here an electric power rectifier is used to lower the voltage of AC line voltage feed to it while changing the AC to DC current. The rectifier is connected to non-consumable anodes that supply DC current to the metal surface to be protected.
- Each type of CP has its separate advantages and disadvantages.

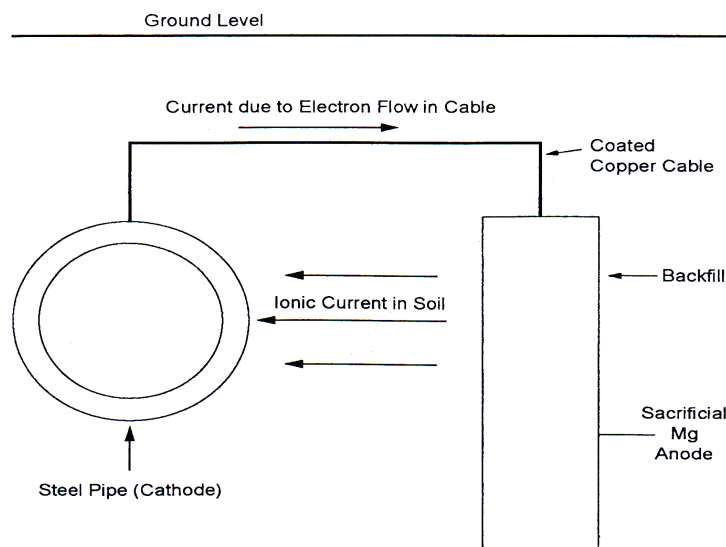

Fig. Principle of cathodic protection with sacrificial anodes

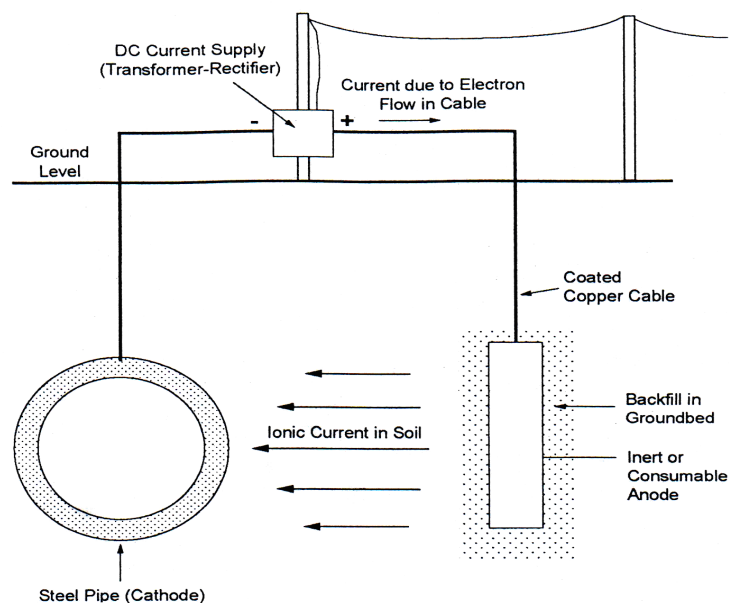

Fig. Principle of cathodic protection with impressed current

4. Chemical Corrosion Inhibitors

- Corrosion inhibitors are solid, liquid or gaseous compounds that are added in small quantities to the given corrosive environment to change its interaction with the metal to be protected.
- Corrosion is an electrochemical process that consists of an oxidation reaction on the anodic site (or sites) of the metal plus one or more reduction reactions on the cathodic site (or sites). These two types of reactions must always occur at the same rate. An effective inhibitor functions by chemically changing one or both of the two reactions so as to slow their rates. Thus the rate of the overall corrosion reaction is reduced to practical levels when a proper inhibitor is applied.
- Using too much or too little can each have negative consequences.
- Inhibitors are most often used in circulating cooling water systems or to treat steam boiler feed water before usage in a boiler. Also can be used in acidic systems, such as, pickling and oil well acidifications.

4.1 Types of Corrosion Inhibitors:

Inhibitors can be classified, as described above, as:

- a. **Adsorption Inhibitors**, which are generally organic compounds, their action is due to blanketing effect over the entire surface of metal, i.e. both anodic and cathodic areas, separating the metal surface from the action of aggressive ions in solution, sometimes cause a considerable reduction in corrosion rate.
- b. **Filming Forming Inhibitors**, their action are appear to act by causing a barrier, or blocking film to be formed of material other than the actual inhibiting species itself, and as mentioned above, it may sub classified as (a) *Anodic film inhibitors*, their function in neutral or alkaline solution and act by producing a passivating oxide film primarily at those parts of the surface where metal cations are formed, i.e. at the anodic sites. And (b) *Cathodic film inhibitors*, they act by inhibiting the cathodic regions without greatly affecting the anodic sites. They are operating by filming the cathodic areas.
- c. **Vapor Phase Inhibitors**, these are substance of low but significant vapor pressure, the vapor of which has corrosion inhibiting properties. They are used to protect critical machine parts, such as ball bearings or other manufactured steel articles, temporarily against rusting by moisture during shipping or storage. On contact with the metal surface the inhibitor vapor condenses and forms the protective layer.

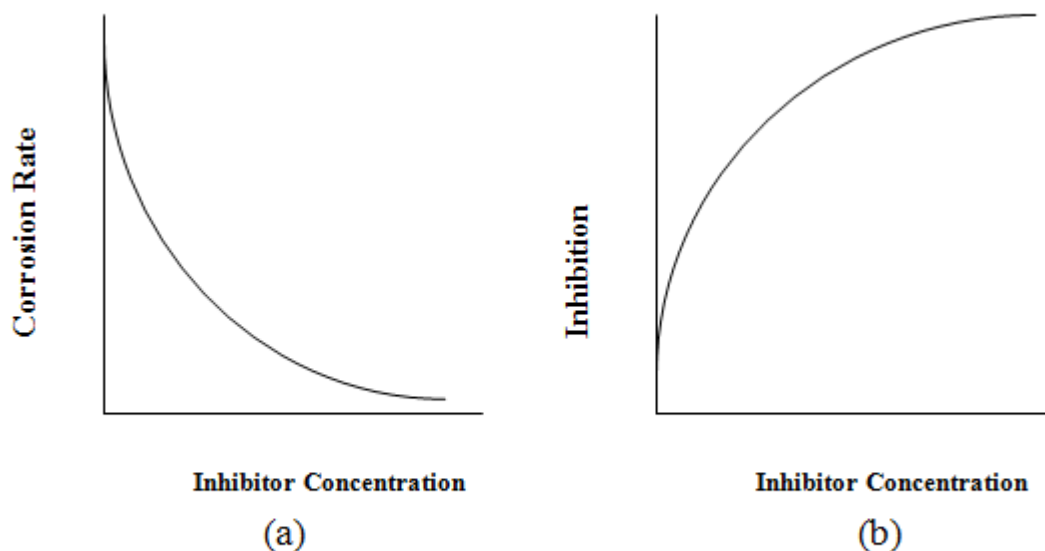

Fig. a- Typical Curves showing drop in corrosion rate as a function of inhibitor concentration.
b- Typical curves showing increased efficiency as a function of inhibitor concentration.

Example:

Two gas pipelines, each of 75 km long and 1 m diameter, are laid in different parts of oil state company at same time. Pipe A with poor epoxy coating, while pipe B is given a high quality coat. Each line is farther protected by impressed current cathodic protection (ICCP) installation which uses 100 V, 100 A (10 kW) to cover the whole length of the pipes. After several years it was found that pipe A required 1.72 mA/m^2 to achieve protection, while pipe B requires $86 \text{ } \mu\text{A/m}^2$. Comment on this case study.

Solution:

Total area of each pipe = $\pi \times D \times L = 3.141 \times 1 \times 75,000 = 239,000 \text{ m}^2$

Total current:

Line A = $1.72 \times 10^{-3} \text{ A/m}^2 \times 239,000 \text{ m}^2 = 411 \text{ A}$

Line B = $86 \times 10^{-6} \text{ A/m}^2 \times 239,000 \text{ m}^2 = 21 \text{ A}$

Line A requires more current than the ICCP able to provide. With poor coating, this pipe is therefore may leak or rupture.

Line B required only 21 A of the 100 A available and this is over design. Therefore, both of pipes with poor ICCP.

Example:

It is planned to place an uncoated steel drilling platform in the sea. The continuous immersed parts of the structure will be protected with a sacrificial cathodic protection system with a life time of 10 years. Determined:

1. The suitable anode (select either Zn or Al)
2. Calculate the minimum number of anodes.

Use the following data: wetted surface area is $2,000 \text{ m}^2$, wetted cross – section area is 500 m^2 , current required for uncoated steel is 110 mA/m^2 , volume wastage rate of zinc is $1.518 \times 10^{-3} \text{ m}^3/\text{A.y}$, $1.18 \times 10^{-3} \text{ m}^3/\text{A.y}$, output of both Zn and Al is 6.5 A/m^2 . Anode is a semi - cylindrical shape with 100 mm diameter and 400 long.

Solution:

Total current required = $2,500 \text{ m}^2 \times 110 \text{ mA/m}^2 = 275 \text{ A}$ and for 10 year = $2,750 \text{ Ay}$

Anode area required = $275 \text{ A} / 6.5 \text{ A/m}^2 = 42.3 \text{ m}^2$.

Area of one anode = $\pi \times D \times L = 3.141 \times 0.4 \times 0.05 = 0.063 \text{ m}^2$

Minimum number of anode = $42.3 \text{ m}^2 / 0.063 \text{ m}^2 = 671$

Total current required for one anode for 10 years = $2,750 \text{ Ay} / 671 \text{ anode} = 4.1 \text{ Ay}$

Volume of zinc wastage = $1.518 \times 10^{-3} \text{ m}^3/\text{A.y} \times 4.1 \text{ Ay} = 0.006 \text{ m}^3$.

Thus all zinc will be consumed after 10 years. Similar work can be repeated for aluminum:

Volume of aluminum wastage = $1.18 \times 10^{-3} \text{ m}^3/\text{A.y} \times 4.1 \text{ Ay} = 0.005 \text{ m}^3$.

Volume of one anode for semi-cylinder = $(\pi \times D^2 \times L/4)/2 = 0.0016 \text{ m}^3$.

Therefore,

anode volume available $0.0016 \text{ m}^3 < \text{Al volume waste } 0.005 \text{ m}^3 < \text{Zn volume waste } 0.006 \text{ m}^3$

and

Al volume waste $< \text{Zn volume waste}$. Then Al is recommended for this system.

Chapter 8

Corrosion Petroleum Industries

Introduction:

Pipelines play an extremely important role through the world as a means of transporting gases and liquids over long distances from their sources to ultimate consumers. So that corrosion problems exist in the oil industry at every stage of production from initial extraction to refining and storage.

Oilfield corrosion manifests itself in several forms, among which

- CO₂ corrosion (sweet corrosion) and
- Hydrogen sulfide (H₂S) corrosion (sour corrosion) in the produced fluids
- Corrosion by oxygen dissolved in water injection

Corrosion of carbon steel is a significant problem in the oil & gas production and transportation systems, which causes:

- Significant economic loss. As a result of corrosion, rupture of the pipe wall frequently causes failure of petroleum and gas pipelines.
- The breakdowns are followed by large losses of the products.
- Environmental pollution and ecological disasters.

Sour Corrosion

- Presence of acidic gases, such as, CO₂ and H₂S produce a serious corrosion problems.
- Sour gas is any gas that specifically contains hydrogen sulfide in significant amounts, whereas an acid gas is any gas that contains significant amounts of acidic gases such as carbon dioxide (CO₂) or hydrogen sulfide.
- Thus, carbon dioxide by itself is an acid gas, not a sour gas.

Corrosion types due to acidic or sour gases:

1. Stress Cracking Corrosion (SCC).
2. Sulfide Stress Cracking (SSC).
3. Hydrogen Induced Cracking (HIC).

Corrosion by H₂S:

Corrosion increased with H₂S concentration.

$$P_{H_2S} < 0.3 \text{ kPa} \quad (0.05 \text{ psi}) \quad \text{Not sour service}$$

$$P_{H_2S} \geq 0.3 \text{ kPa} \quad (0.05 \text{ psi}) \quad \text{sour service}$$

According to NACE MR0175/ISO15156 corrosion by H₂S can be related with pH according to figure below. The partial pressure of the gas can be calculated from mole fraction and total pressure as follows:

$$P_{H_2S} = P_T y_{H_2S}$$

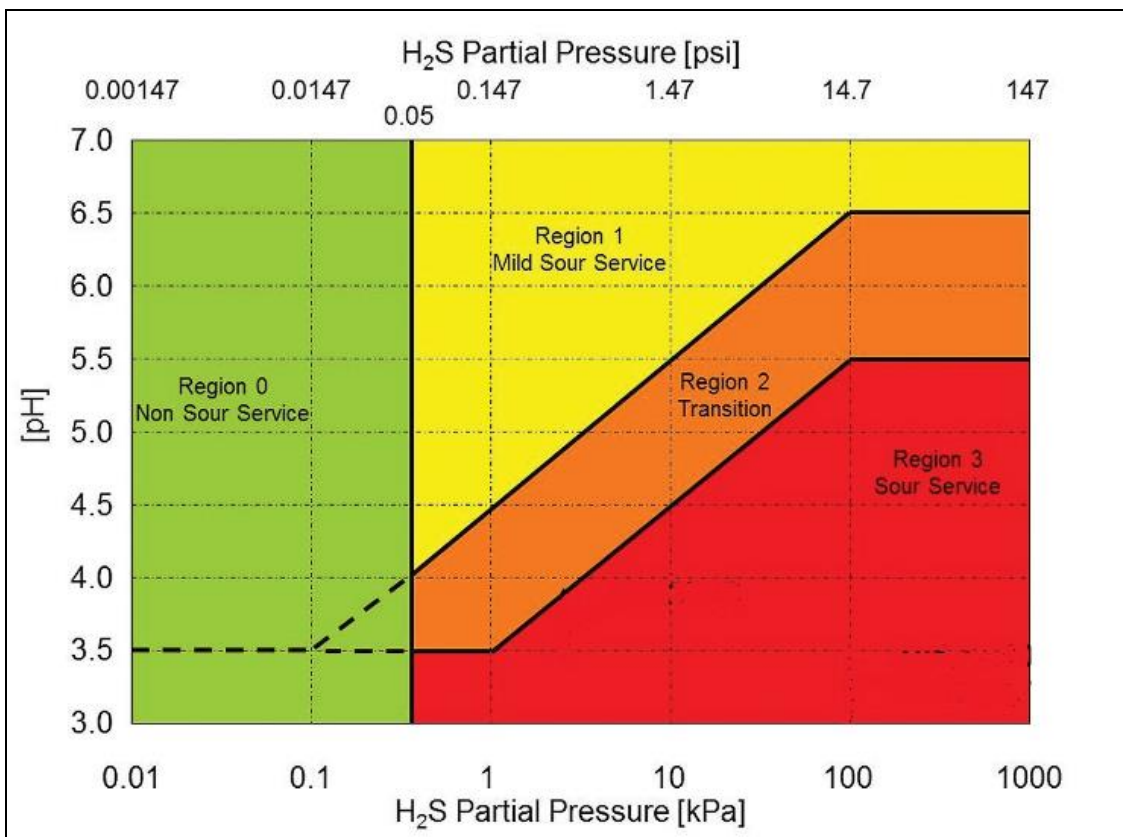

Corrosion CO₂:

Corrosion increased with CO₂ concentration.

$$P_{CO_2} < 7 \text{ psi } (0.5 \text{ bar}) \quad (\text{Nocorrosion})$$

$$7 \text{ psi } (0.5 \text{ bar}) < P_{CO_2} < 30 \text{ psi } (2 \text{ bar}) \quad (\text{possiblecorrosion})$$

$$P_{CO_2} > 30 \text{ psi } (2 \text{ bar}) \quad (\text{corrosion})$$

Empirical equation for calculation of corrosion rate by CO₂:

$$\log(\text{c.r., mm / y}) = 5.8 - \frac{1780}{T} + 0.67 \log(pCO_2)$$

Where T in °C and P in bar.

Corrosion by combined effect of H₂S and CO₂:

Corrosion by sour and acidic gases depend on partial pressure

$$\frac{P_{CO_2}}{P_{H_2S}} > 500 \quad CO_2 \text{ corrosion}$$

$$\frac{P_{CO_2}}{P_{H_2S}} < 20 \quad H_2S \text{ corrosion}$$

$$20 < \frac{P_{CO_2}}{P_{H_2S}} < 500 \quad H_2S \text{ and } CO_2 \text{ corrosion}$$

Solved problems

1. The charge of an electron is $1,58 \times 10^{-19}$ C.

a) What is the charge of an Al ion?

b) If 0,068 moles of Al^{+++} cross a given section in 1 hour, what is the current in amps?

Answer:

$$\text{a) } 3 \times 1,58 \times 10^{-19} \quad C = 4,74 \times 10^{-19} \text{ C}$$

b) 0,068 moles Al^{+++}

$$\text{charge} = 0,068 \text{ moles} \times 6,023 \times 10^{23} \text{ ion/mole} \times 3 \text{ ch/ion} \times 1,58 \times 10^{-19} \text{ C}$$

$$\text{charge} = 1,94 \times 10^4 \text{ C}$$

$$I = \frac{1,94 \times 10^4 \text{ C}}{3600 \text{ S}} = 5,39 \text{ A}$$

$$I = 5,39 \text{ A}$$

2. Compute the weight of one molecule of O_2 .

Answer:

One mole of any molecular substance contains the same number of molecules, Avogadro's number:

$$N = 6,023 \times 10^{23} \text{ molecules/mole}$$

One mole of $\text{O}_2 = 32$ g.

$$\frac{32 \text{ g/mol}}{6,023 \times 10^{23} \text{ molecule/mol}} = 5,3 \times 10^{-23} \text{ g/molecule}$$

3.

A galvanic cell is formed by an iron electrode immersed in a Fe^{++} solution (potential: -0,5 V) and a copper electrode immersed in a Cu^{++} solution (potential: + 0,30 V).

a) Sketch a figure representing that cell.

b) Indicate the signs of the electrode and the direction of the spontaneous flow of electrons. A diaphragm separates the two solutions.

c) Give the reactions at the electrode and indicate which is oxidation, reduction, anode and cathode.

d) Compute the maximum cell potential and the free energy per mole of reacting iron.

Answer:

a) See Figure I-11.

b) See Figure I-11.

c) $\text{Fe} \rightarrow \text{Fe}^{++} + 2e^-$, which is an oxidation taking place at the anode
 $\text{Cu}^{++} + 2e^- \rightarrow \text{Cu}$, which is the reduction at the cathode.

d) $E_{\text{cell}} = E_C - E_A = E_{\text{Cu}} - E_{\text{Fe}} = 0,3 - (-0,5) = +0,8 \text{ V}$
 $\Delta G = -nFE_{\text{cell}} = -2 \text{ equ/mol} \times 23\,060 \text{ cal/Vequ} \times 0,8 \text{ V}$
 $= -37 \text{ kcal/mole}$

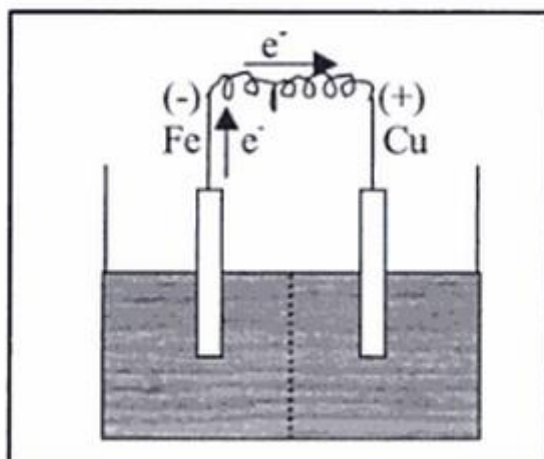

Figure I-11 A galvanic power source

4.

Copper is purified in an electrolytic process called electrorefining. Impure copper is dissolved at the anode and pure copper is deposited at the cathode. The two electrode reactions proceed under an imposed direct current. The electrolyte is an acid CuSO_4 aqueous solution.

- Sketch the electrolysis cell, showing the direction of electron flow.
- Indicate the sign at each electrode when a current is impressed.
- Give the main electrochemical reaction at each electrode and specify which is the cathode and the anode.
- Explain what happens to the impurities Fe, Ni and Au. (Use a simplified potential scale.)

Answer:

- Figure I-12: Electrorefining of copper.
- Electrode X is positive; electrode Y is negative. The current of electrons goes from X to Y. (P.G. \equiv power generator).
- Electrode X: $\text{Cu} \rightarrow \text{Cu}^{++} + 2\text{e}^-$ oxidation, anode (A).
Electrode Y: $\text{Cu}^{++} + 2\text{e}^- \rightarrow \text{Cu}$ reduction, cathode (C).

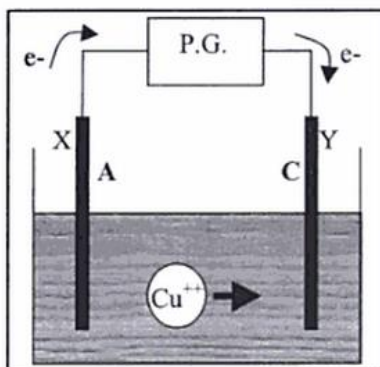

Figure I-12 Electrorefining of copper

- d) It can be seen from the potential scale that gold is more noble than all other metals (Fig. I-13).

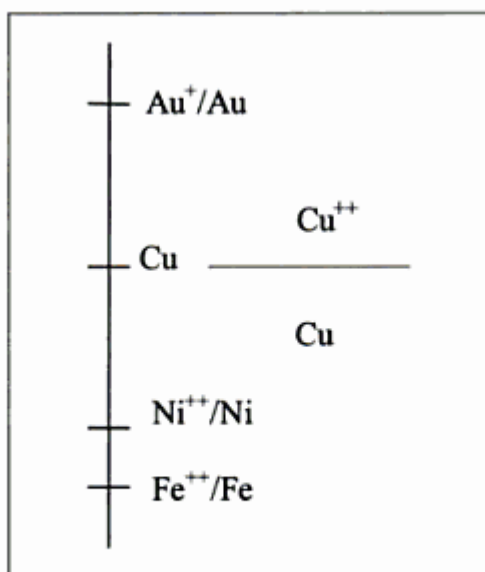
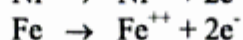
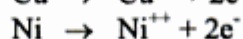
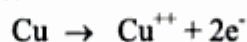

Figure I-13 The potential scale for Cu electrowinning.

At the anode (impure copper), the imposed potential is above the equilibrium potential for Cu^{++}/Cu (Fig. I-13) which is in the domain of stability of Cu^{++} , Ni^{++} and Fe^{++} . Oxidation of these metals then proceeds:



Gold is stable as the metal Au. It does not oxidize. Gold powder falls to the bottom of the cell.

At the cathode, the reduction of copper requires a potential E_C below the equilibrium potential for Cu^{++}/Cu . This potential, however, remains at a value above the Ni^{++}/Ni equilibrium. Fe^{++}/Fe , Ni^{++} and Fe^{++} then remain stable and are not reduced. Pure Cu alone deposits then on the cathode, and the impure anode is purified.

5.

A buried steel pipe can be protected using a magnesium electrode.

- Sketch the system.
- Using a simplified potential scale indicate the sign of each electrode and show the direction of the electron flow in the wire that connects the pipe to the magnesium electrode.
- Give the electrochemical reaction taking place at each electrode, and indicate which is oxidation and which is reduction.
- Indicate which electrode is the anode and which is the cathode.
- Is such a system galvanic or electrolytic? Why?

Answers:

a) Figure I-14.

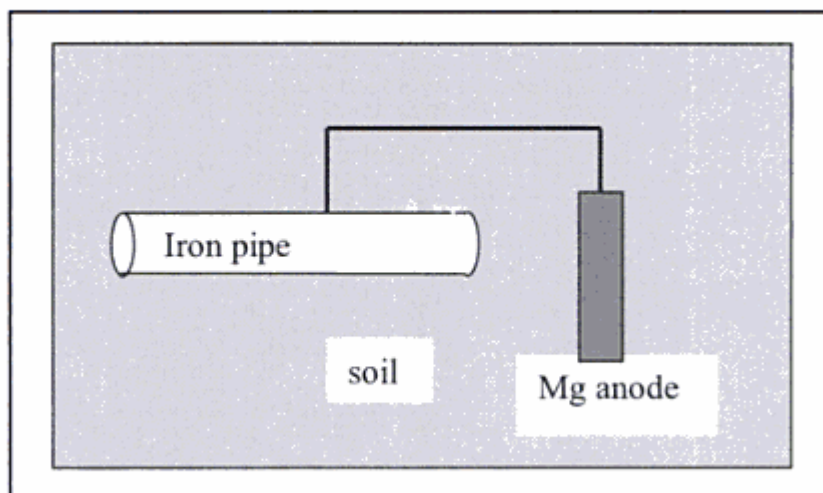
**Figure I-14** Cathodic protection with sacrificial anode

- b) The magnesium is negative and the iron is positive. Electrons flow spontaneously from Mg to Fe.
- c) At the *positive* Fe electrode, an excess of electrons arrive. They react with water, since there are no Fe^{++} ions there.

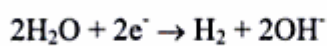

This is a reduction.

At the *negative* Mg electrode, electrons flow away. The reaction (an oxidation) is:



- d) Since Fe supports a reduction reaction, it is the cathode. Mg, which is oxidized, is the anode.
- e) The electrons flow spontaneously, due to the difference of charge of the electrodes. It is then a galvanic system.

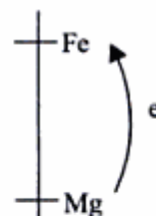

6.

An electrochemical cell can be formed with hydrogen and oxygen reactions on a platinum plate used as a non-reactive support for the two electrode reactions. Explain both the galvanic and electrolytic behavior that can be imposed on this system. Use a simplified potential scale to support your explanation. In each case answer the following questions:

- Sketch the cell.
- Give the sign of the electrode and the direction of the electron flow.
- Give the electrode reactions and identify the anode and the cathode.

Answers:

a)

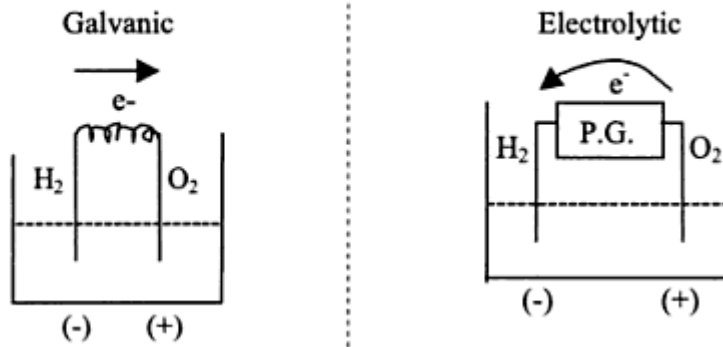

b)

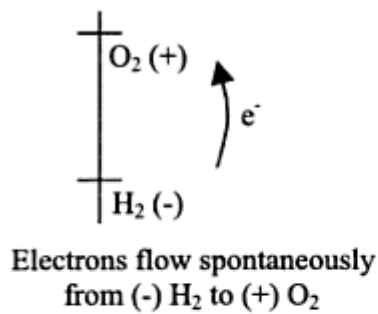

The power generator forces the flow of electrons from (+) O₂ to (-) H₂

The current (flow of electrons) has changed direction.

c)

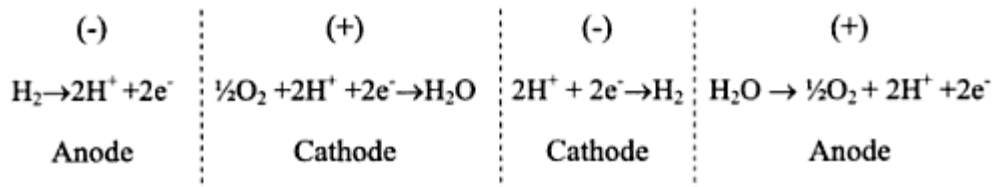

In the galvanic and electrolytic cells, the positive and negative electrodes remain the same, but the electrochemical reactions and the anodes and cathodes are reversed:

	Galvanic	Electrolytic
H ⁺ /H ₂	Anode	Cathode
O ₂	Cathode	Anode

7.

If one mole of tin is consumed in the **corrosion** cell $\text{Sn}/\text{Sn}^{2+} // \text{Cu}^{2+}/\text{Cu}$, calculate the change of the Gibbs free-energy, ΔG .

Solution:

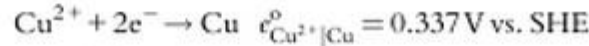

Tin will corrode when coupled with the copper.

$$E_{\text{cell}}^{\circ} = e_{\text{Cu}^{2+}|\text{Cu}}^{\circ} - e_{\text{Sn}^{2+}|\text{Sn}}^{\circ} = 0.337 + 0.138 = 0.475 \text{ V vs. SHE}$$

The Gibbs free-energy change when one mole of tin is consumed is:

$$\Delta G = -nFE^{\circ} = -2 \times 96,485 \times 0.475 = -91.7 \text{ kJ}$$

8.

Calculate the half-cell potential of Ni in 0.1 M NiCl_2 solution. The half-cell is represented as: $\text{Ni}|\text{Ni}^{2+}, \text{Cl}^{-} (0.1 \text{ M})$.

Solution:

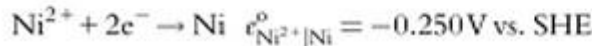

$$e_{\text{Ni}^{2+}|\text{Ni}} = e_{\text{Ni}^{2+}|\text{Ni}}^{\circ} - 2.303 \frac{RT}{2F} \log \left(\frac{a_{\text{Ni}}}{a_{\text{Ni}^{2+}}} \right) = -0.250 + \frac{0.059}{2} \log(a_{\text{Ni}^{2+}})$$

$$e_{\text{Ni}^{2+}|\text{Ni}} = -0.250 + \frac{0.059}{2} \log(0.1 \text{ M}) = -0.280 \text{ V vs. SHE}$$

9.

Estimate the equilibrium constant for the reaction:

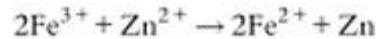

Solution:

The half cell reactions are:

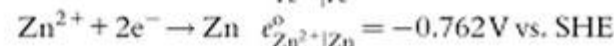

Because

$$\Delta G^{\circ} = -2.303RT \ln K = -nFE_{\text{cell}}^{\circ}$$

$$\log K = \frac{nE_{\text{cell}}^{\circ}}{0.059}$$

The electrode potentials for the individual half-cell reactions are:

$$e_{\text{Fe}^{3+}|\text{Fe}^{2+}} = 0.771 - 2.303 \frac{RT}{2F} \log \left(\frac{a_{\text{Fe}^{2+}}}{a_{\text{Fe}^{3+}}} \right)$$

$$e_{\text{Zn}^{2+}|\text{Zn}} = -0.762 - 2.303 \frac{RT}{2F} \log \left(\frac{a_{\text{Zn}}}{a_{\text{Zn}^{2+}}} \right)$$

Because the equilibrium constant is a ratio between the activities of the products and reactants, it follows that:

$$0.771 - 2.303 \frac{RT}{2F} \log \left(\frac{a_{\text{Fe}^{2+}}}{a_{\text{Fe}^{3+}}} \right) = -0.762 - 2.303 \frac{RT}{2F} \log \left(\frac{a_{\text{Zn}}}{a_{\text{Zn}^{2+}}} \right)$$

$$\log \left(\frac{a_{\text{Fe}^{2+}} + a_{\text{Zn}^{2+}}}{a_{\text{Fe}^{3+}} + a_{\text{Zn}}} \right) = \frac{(0.771 + 0.762) \times 2}{0.059} = 52 = \log(K)$$

$$K = 10^{52}$$

10.

What is the emf of a cell constructed from a lead electrode in lead sulfate of pH = 1 with activity of $\text{Pb}^{2+} = 0.01$ and a hydrogen electrode?

Solution:

Cell Notation: $\text{Pb} | \text{Pb}^{2+}, \text{SO}_4^{2-}, \text{H}^+ | \text{H}_2$

Cell Reactions (assumption):

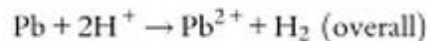
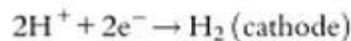
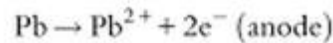

$$e_{\text{H}^+|\text{H}_2} = 0 - 2.303 \frac{RT}{2F} \log \left(\frac{P_{\text{H}_2}}{(a_{\text{H}^+})^2} \right)$$

$$e_{\text{Pb}|\text{Pb}^{2+}} = 0.126 - 2.303 \frac{RT}{2F} \log \left(\frac{a_{\text{Pb}^{2+}}}{a_{\text{Pb}}} \right)$$

$$E_{\text{cell}} = 0.126 - 2.303 \frac{RT}{2F} \log \left(\frac{a_{\text{Pb}^{2+}}}{(a_{\text{H}^+})^2} \right)$$

$$E_{\text{cell}} = 0.126 - \frac{0.059}{2} \log \left(\frac{0.01}{(0.1)^2} \right) = 0.126 \text{ V vs. SHE}$$

The cell potential is positive, indicating that the reaction proceeds spontaneously. The lead will corrode, while the hydrogen electrode will serve as the cathode.

11.

Determine whether tin is stable in 10^{-6} M Sn^{2+} acid solution of $\text{pH} = 2$. Estimate (a) the Gibbs free-energy change and (b) the cell potential for the corrosion cell. The activity coefficients are assumed to be 1. The hydrogen pressure is 1 atm.

Solution:

Half-cell reactions:

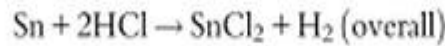
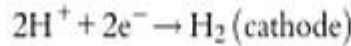
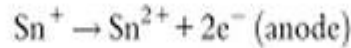

$$e_{\text{H}^+|\text{H}_2} = 0 - 2.303 \frac{RT}{2F} \log \left(\frac{P_{\text{H}_2}}{(a_{\text{H}^+})^2} \right)$$

$$e_{\text{Sn}|\text{Sn}^{2+}} = 0.138 - 2.303 \frac{RT}{2F} \log \left(\frac{a_{\text{Sn}^{2+}}}{a_{\text{Sn}}} \right)$$

$$E_{\text{cell}} = e_a + e_c$$

$$E_{\text{cell}} = 0 + 0.138 - 2.303 \frac{RT}{2F} \log \left(\frac{P_{\text{H}_2} a_{\text{Sn}^{2+}}}{(a_{\text{H}^+})^2 a_{\text{Sn}}} \right)$$

$$E_{\text{cell}} = 0.138 - \frac{0.059}{2} \log \left(\frac{10^{-6}}{(10^{-2})^2} \right) = 0.197 \text{ V vs. SHE}$$

The Gibbs free-energy is calculated by using the Eq. (2.45):

$$-\frac{\Delta G}{nF} = E_{\text{cell}} = \left[e_{\text{H}^+|\text{H}_2}^0 + \frac{RT}{nF} \ln \left(\frac{a_{\text{H}^+}^2}{P_{\text{H}_2}} \right) \right] - \left[e_{\text{M}^{n+}|\text{M}}^0 + \frac{RT}{nF} \ln (a_{\text{M}^{n+}}) \right] \quad (2.45)$$

or

$$\Delta G_{\text{Sn}} = -nFE_{\text{cell}} = -2 \times 96,500 \times 0.197 = -38.021 \frac{\text{kJ}}{\text{mol}}$$

Because Gibbs free-energy change is negative, tin dissolves at $\text{pH} = 2$.

12.

For the cell at 25 °C, $\text{Cu}|\text{Cu}^{2+} (a=1)||\text{Fe}^{2+}|\text{Fe} (a=1)$ determine if the reaction will proceed spontaneously as written?

Cell Reactions:

Solution:

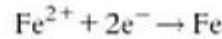

$$E_{\text{cell}}^{\circ} = e_{\text{Fe}^{2+}|\text{Fe}}^{\circ} + e_{\text{Cu}|\text{Cu}^{2+}}^{\circ} = -0.440 - 0.337 = -0.777 \text{ V vs. SHE}$$

$$\Delta G^{\circ} = -nFE_{\text{cell}}^{\circ} = -2 \times 96,485 \times (-0.777) = 150 \frac{\text{kJ}}{\text{mol}} > 0$$

The reaction will not proceed spontaneously as written.

The spontaneous reaction is:

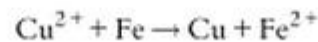

13.

Determine whether Fe is stable in 10^{-6} M aerated water solution of Fe^{2+} at a pH of 8. Estimate (a) the Gibbs free-energy change and (b) the cell potential of the corrosion cell. The activity coefficients are assumed to be 1. The hydrogen pressure is 1 atm.

Solution:

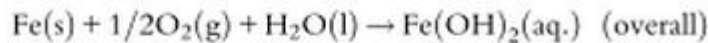
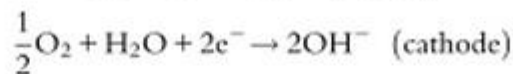
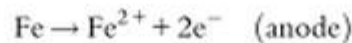

$$e_{\text{O}_2|\text{OH}^{-}} = 0.401 - 2.303 \frac{RT}{2F} \log \left(\frac{(a_{\text{OH}^{-}})^2}{P_{\text{O}_2}} \right)$$

$$e_{\text{Fe}|\text{Fe}^{2+}} = 0.440 - 2.303 \frac{RT}{2F} \log \left(\frac{a_{\text{Fe}^{2+}}}{a_{\text{Fe}}} \right)$$

$$E_{\text{cell}} = 0.401 + 0.440 - 2.303 \frac{RT}{2F} \log \left(\frac{(a_{\text{OH}^{-}})^2 a_{\text{Fe}^{2+}}}{P_{\text{O}_2} a_{\text{Fe}}} \right)$$

This simplifies to:

$$E_{\text{cell}} = 0.841 - \frac{0.059}{2} \log \left(10^{-6} (10^{-6})^2 \right) = 1.372 \text{ V vs. SHE}$$

The Gibbs free-energy is calculated by using the Eq. (2.45)

$$-\frac{\Delta G}{nF} = E_{\text{cell}} = \left[e_{\text{H}^{+}|\text{H}_2}^{\circ} + \frac{RT}{nF} \ln \left(\frac{a_{\text{H}^{+}}^2}{P_{\text{H}_2}} \right) \right] - \left[e_{\text{M}^{n+}|\text{M}}^{\circ} + \frac{RT}{nF} \ln (a_{\text{M}^{n+}}) \right]$$

$$\Delta G_{\text{Fe}|\text{O}_2} = -nFE = -2 \times 96,485 \times 1.372 = -264.8 \frac{\text{kJ}}{\text{mol}}$$

Because the Gibbs free-energy is negative, the reaction will proceed spontaneously as written. Iron will dissolve in aerated solution at pH of 8.

14.

Estimate the theoretical tendency for zinc to corrode (emf) when immersed in 10^{-6} to 10^{-1} M ZnCl_2 solution at pH of 3. The corrosion cell is described as:

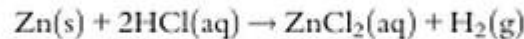
**Solution:**

The overall reaction can be written as:



The Nernst equations for the anode, cathode, and overall reactions are as follows:

$$e_{\text{Zn}|\text{Zn}^{2+}} = e_{\text{Zn}|\text{Zn}^{2+}}^{\circ} - 2.303 \frac{RT}{2F} \log \left(\frac{a_{\text{Zn}^{2+}}}{a_{\text{Zn}}} \right) \quad (\text{anode})$$

$$e_{\text{H}^+|\text{H}_2} = e_{\text{H}^+|\text{H}_2}^{\circ} - 2.303 \frac{RT}{2F} \log \left(\frac{a_{\text{H}_2}}{(a_{\text{H}^+})^2} \right) \quad (\text{cathode})$$

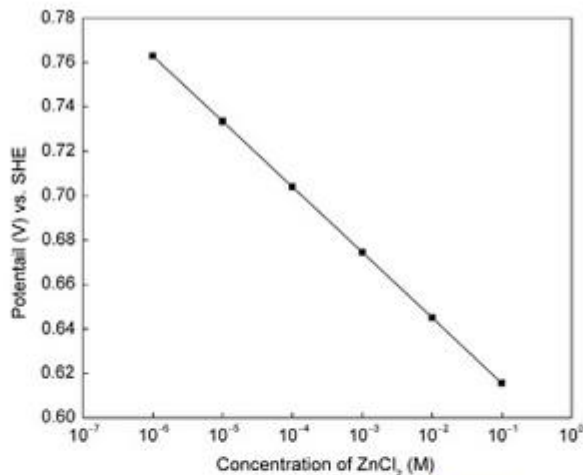

Fig. 2.23 Plot of ZnCl_2 concentrations vs. cell potential for the Zn corrosion cell.

$$E_{\text{cell}} = e_{\text{H}^+|\text{H}_2} + e_{\text{Zn}|\text{Zn}^{2+}} = e_{\text{H}^+|\text{H}_2}^{\circ} + e_{\text{Zn}|\text{Zn}^{2+}}^{\circ} - 2.303 \frac{RT}{2F} \log \left(\frac{a_{\text{H}_2} a_{\text{Zn}^{2+}}}{(a_{\text{H}^+})^2 a_{\text{Zn}}} \right) \quad (\text{overall})$$

$$E_{\text{cell}} = 0 + 0.762 - \frac{0.059}{2} \log \left(\frac{a_{\text{Zn}^{2+}}}{(a_{\text{H}^+})^2} \right)$$

For pH 3, the above equation can be written as:

$$E_{\text{cell}} = 0.762 - \frac{0.059}{2} \log(a_{\text{Zn}^{2+}}) - 0.059\text{pH}$$

By substituting the ZnCl_2 concentrations at pH=3 in the above expression, the tendency of zinc to corrode in volts was calculated and presented in Fig. 2.23. The results indicate that the tendency of zinc to corrode increases with decreasing the concentration of zinc ions at the electrode interface.

15.

Estimate the hydrogen pressure (fugacity) necessary to stop the corrosion of cobalt in 0.1 M Co^{2+} solution at pH of 1, 3, 5, and 7.

Solution:

To stop the corrosion process, the EMF of the cell should be zero or positive. The standard equilibrium potential for the reaction:

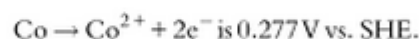

The Nernst equation for the reaction:

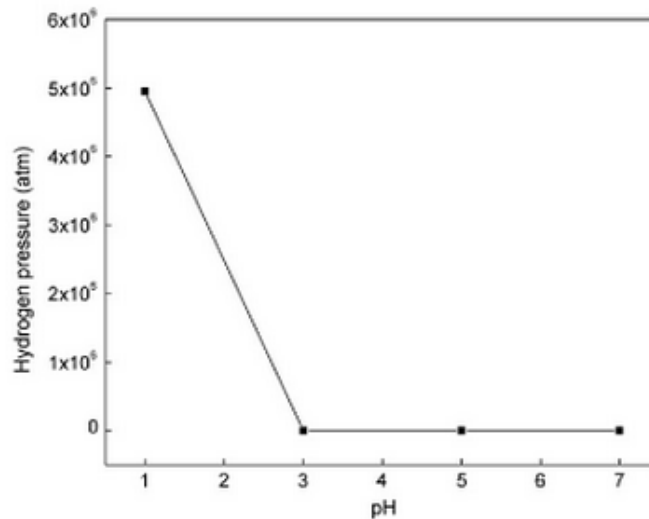
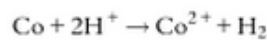

Fig. 2.24 Dependence of fugacity on pH for the cobalt system.



is written as:

$$E_{\text{cell}} = e_{\text{Co}|\text{Co}^{2+}}^{\circ} + e_{\text{H}^+|\text{H}_2}^{\circ} - 2.303 \frac{RT}{2F} \log \left(\frac{a_{\text{Co}/\text{Co}^{2+}} P_{\text{H}_2}}{[\text{a}_{\text{H}^+}]^2} \right)$$

$$E_{\text{cell}} = 0.277 - \frac{0.059}{2} \log \left(\frac{[0.1] \times P_{\text{H}_2}}{[\text{a}_{\text{H}^+}]^2} \right) = 0$$

$$P_{\text{H}_2} = \frac{10^{\frac{0.277 \times 2}{0.059}} (\text{a}_{\text{H}^+})^2}{0.1}$$

The hydrogen pressure necessary to stop corrosion of Co is calculated by substituting appropriate pH values in the above equation and equating to zero. The plot of pH vs. hydrogen pressure (Fig. 2.24) indicates that below pH=3, the hydrogen pressure cannot stop cobalt from corroding. Thus, increasing hydrogen pressure is not a feasible solution to stop the corrosion of cobalt in acidic solutions.

16.

Determine the tendency of zinc to corrode in 0.6 M ZnCl_2 solution at pH between 0 and 5.

Cell notation: $\text{Zn}|\text{Zn}^{2+}, \text{Cl}^-, \text{H}^+|\text{H}_2|\text{Pt}$

Cell reactions: $\text{Zn} \rightarrow \text{Zn}^{2+} + 2\text{e}^-$ (anode)

$2\text{H}^+ + 2\text{e}^- \rightarrow \text{H}_2$ (cathode)

Solution:

Zinc is oxidized at the anode and the H^+ is reduced at the cathode. The only terms that one should consider are those for the Zn^{2+} and the H^+ concentrations. The activities of

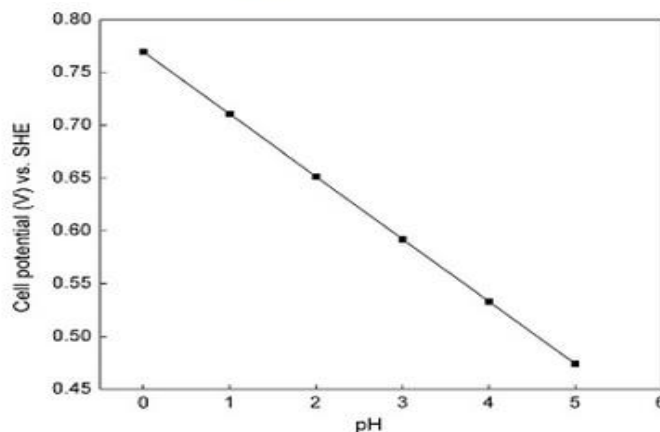

Fig. 2.25 Dependence of cell potential on pH for the Zn system.

metallic Zn and H_2 are assumed to be unity. Because Zn^{2+} is formed (product), it will appear in the numerator of the logarithmic term, and the H^+ (reactant) will appear in the denominator. The problem requires changing the H^+ concentration in line with the pH in order to calculate the cell potential at different pH values. The general Nernst equation for the overall reaction is:

$$E_{\text{cell}} = e_{H^+|H_2}^0 + e_{Zn|Zn^{2+}}^0 - 2.303 \frac{RT}{2F} \log \left(\frac{a_{Zn^{2+}}}{(a_{H^+})^2} \right)$$

$$E_{\text{cell}} = 0 + 0.762 - \frac{0.059}{2} \log \left(\frac{a_{Zn^{2+}}}{(a_{H^+})^2} \right)$$

$$E_{\text{cell}} = 0.762 - \frac{0.059}{2} \log(0.6) - 0.059 \text{pH}$$

$$E_{\text{cell}} = 0.769 \text{V vs. SHE (for pH} = 0)$$

The plot of pH vs. the cell potential (Fig. 2.25) indicates that, for an increase of the pH of 1, there is a decrease in the cell potential of 0.059 mV.

17.

Calculate the theoretical tendency of nickel to corrode (in volts) with evolution of hydrogen when immersed in 0.02 M $NiCl_2$, acidified to pH = 6.

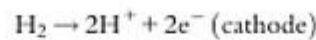

Solution:

The Nernst equation for the overall reaction can be written as:

$$E_{\text{cell}} = e_{H^+|H_2}^0 + e_{Ni|Ni^{2+}}^0 = e_{H^+|H_2}^0 + e_{Ni|Ni^{2+}}^0 - 2.303 \frac{RT}{2F} \log \left(\frac{P_{H_2} a_{Ni^{2+}}}{(a_{H^+})^2 a_{Ni}} \right)$$

$$E_{\text{cell}} = 0 + 0.250 + 2.303 \frac{RT}{2F} \log \left(\frac{(a_{H^+})^2}{a_{Ni^{2+}}} \right)$$

$$E_{\text{cell}} = 0.250 + \frac{0.059}{2} \log \left(\frac{(10^{-6})^2}{0.02} \right)$$

$$E_{\text{cell}} = -0.05 \text{V vs. SHE}$$

The Gibbs free-energy is calculated by using the expression:

$$\Delta G = -nFE$$

$$\Delta G = -2 \times 96,485 \times (-0.05) = 9.65 \text{kJ/mol}$$

Nickel does not corrode at pH = 6.

18.

Calculate the driving emf for the corrosion cell and write the spontaneous reaction for the following cell:

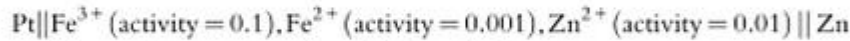

The iron redox reaction is assumed to be the cathode.

The half-cell reactions and the overall reaction are:

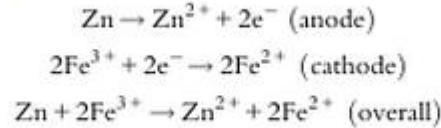

Solution:

The Nernst equations for the anode, cathode, and overall reactions are as follows:

$$e_{\text{Zn}|\text{Zn}^{2+}} = e_{\text{Zn}|\text{Zn}^{2+}}^{\circ} - 2.303 \frac{RT}{2F} \log \left(\frac{a_{\text{Zn}^{2+}}}{a_{\text{Zn}}} \right) \quad (\text{anode})$$

$$e_{\text{Fe}^{3+}|\text{Fe}^{2+}} = e_{\text{Fe}^{3+}|\text{Fe}^{2+}}^{\circ} - 2.303 \frac{RT}{2F} \log \left(\frac{(a_{\text{Fe}^{2+}})^2}{(a_{\text{Fe}^{3+}})^2} \right) \quad (\text{cathode})$$

$$\begin{aligned} E_{\text{cell}} &= e_{\text{Fe}^{3+}|\text{Fe}^{2+}} + e_{\text{Zn}|\text{Zn}^{2+}} \\ &= e_{\text{Fe}^{3+}|\text{Fe}^{2+}}^{\circ} + e_{\text{Zn}|\text{Zn}^{2+}}^{\circ} - 2.303 \frac{RT}{2F} \log \left(\frac{(a_{\text{Fe}^{2+}})^2 a_{\text{Zn}^{2+}}}{(a_{\text{Fe}^{3+}})^2} \right) \quad (\text{overall}) \end{aligned}$$

$$E_{\text{cell}} = 0.762 + 0.771 + 2.303 \frac{RT}{2F} \log \left(\frac{(0.001)^2 0.01}{0.1} \right)$$

$$E_{\text{cell}} = 1.326 \text{ V vs. SHE}$$

The Gibbs free-energy is calculated by using the expression:

$$\Delta G = -nFE_{\text{cell}}$$

Because ΔG is negative, the Fe^{3+} cation will oxidize zinc to zinc ion by reducing itself to Fe^{2+} .

19.

Tin is immersed in a solution of CuCl_2 with activity of $\text{Cu}^{2+} = 0.2$. Determine the concentration of Sn^{2+} at which the corrosion will stop.

Solution:

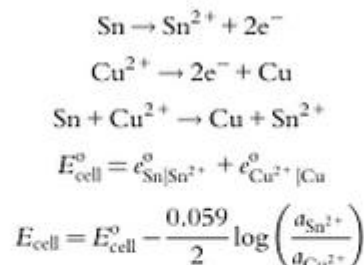

The reaction stops when the cell emf is zero.

$$\begin{aligned} E_{\text{cell}} = E_{\text{cell}}^{\circ} - \frac{0.059}{2} \log \left(\frac{a_{\text{Sn}^{2+}}}{a_{\text{Cu}^{2+}}} \right) &= 0 \quad \frac{2 \times 0.475}{0.059} = \log \left(\frac{a_{\text{Sn}^{2+}}}{a_{\text{Cu}^{2+}}} \right) \\ a_{\text{Sn}^{2+}} &= 10^{\frac{0.95}{0.059}} \times a_{\text{Cu}^{2+}} = 2.53 \times 10^{16} \text{ M} \end{aligned}$$

The corrosion will stop when Sn^{2+} concentration reaches $2.53 \times 10^{16} \text{ M}$ at the electrode interface.

20.

- (a) Calculate the pressure (fugacity) of hydrogen required to stop corrosion of nickel immersed in 0.05 M NiCl₂, pH = 2.
 (b) Compare the results for the fugacity to stop the corrosion of iron immersed in 0.05 M FeCl₂ at a pH of 2.

Solution:(a) Ni in NiCl₂ at pH = 2

Cell Notation

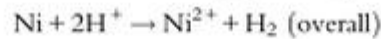
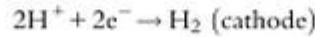
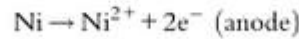

$$e_{\text{H}^+|\text{H}_2} = 0 - 2.303 \frac{RT}{2F} \log \left(\frac{P_{\text{H}_2}}{(a_{\text{H}^+})^2} \right)$$

$$e_{\text{Ni}|\text{Ni}^{2+}} = 0.250 - 2.303 \frac{RT}{2F} \log \left(\frac{a_{\text{Ni}^{2+}}}{a_{\text{Ni}}} \right)$$

$$E_{\text{cell}} = 0 + 0.250 - 2.303 \frac{RT}{2F} \log \left(\frac{P_{\text{H}_2} a_{\text{Ni}^{2+}}}{(a_{\text{H}^+})^2 a_{\text{Ni}}} \right)$$

This simplifies to:

$$E_{\text{cell}} = 0 = 0.250 + \frac{0.059}{2} \log \left(\frac{P_{\text{H}_2} a_{\text{Ni}^{2+}}}{(a_{\text{H}^+})^2} \right) = 0.250 - \frac{0.059}{2} \log \left(\frac{0.05 P_{\text{H}_2}}{(a_{\text{H}^+})^2} \right)$$

$$\frac{0.500}{0.059} = \log \left(\frac{0.05 P_{\text{H}_2}}{(10^{-2})^2} \right)$$

$$P_{\text{H}_2} = \frac{(10^{0.500/0.059})(10^{-2})^2}{0.05} = 5.965 \times 10^5 \text{ atm}$$

(b) For FeCl₂ at a pH of 2:

Cell Notation:

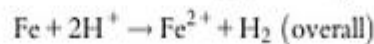
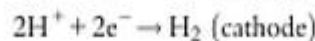
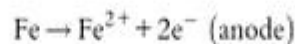

$$e_{\text{H}^+|\text{H}_2} = 0 - 2.303 \frac{RT}{2F} \log \left(\frac{P_{\text{H}_2}}{(a_{\text{H}^+})^2} \right)$$

$$e_{\text{Fe}|\text{Fe}^{2+}} = 0.440 - 2.303 \frac{RT}{2F} \log \left(\frac{a_{\text{Fe}^{2+}}}{a_{\text{Fe}}} \right)$$

21.

The potential of an iron electrode when polarized as a cathode in an aqueous medium is -0.716 V vs. SCE. What would be the value of the hydrogen overpotential of this electrode in an electrolyte with a pH of 2.0?

Solution:

The hydrogen overpotential, η , is the difference between the potential of iron electrode ($E = -0.716$ V vs. SCE) and the potential of the hydrogen reaction.

$$\eta = E - e_{\text{eq}}$$

For the hydrogen reaction $2\text{H}^+ + 2\text{e}^- \rightarrow \text{H}_2$, $e_{\text{H}^+|\text{H}_2}^0 = 0.00$ V vs. SHE or $e_{\text{H}^+|\text{H}_2}^0 = -0.241$ vs. SCE

$$\begin{aligned} e_{\text{eq,H}^+|\text{H}_2} &= e_{\text{H}^+|\text{H}_2}^0 - 0.059(\text{pH}) = -0.241 - (0.059 \times 2) \\ &= -0.359 \text{ V vs. SCE} \end{aligned}$$

The hydrogen overpotential is the difference of the potential of iron electrode (-0.716 V vs. SCE) and the potential of the hydrogen reaction.

$$\eta = -0.716 - (-0.359) = -0.357 \text{ V}$$

22.

The potential of an iron electrode when cathodically polarized in an aqueous medium is -0.75 V vs. SHE. Determine the hydrogen overpotential in electrolytes with pH between 1 and 6.

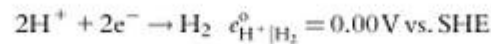
Solution:

$$e_{\text{eq,H}^+|\text{H}_2} = e_{\text{H}^+|\text{H}_2}^0 - 2.303 \frac{RT}{nF} \log \left(\frac{a_{\text{H}_2}}{(a_{\text{H}^+})^2} \right)$$

The hydrogen overpotential is the difference of the potential of the iron electrode and the potential of hydrogen reaction.

$$\eta = E - e_{\text{eq}}$$

$$\eta_{\text{eq,H}^+|\text{H}_2} = 0 - 0.059(\text{pH})$$

$$e_{\text{eq,H}^+|\text{H}_2} = -0.059(\text{pH})$$

$$\eta_{\text{H}_2} = -0.75 - e_{\text{eq,H}^+|\text{H}_2}$$

$$\eta_{\text{H}_2} = -0.75 + 0.059(\text{pH})$$

At a pH of 1,

$$\eta_{\text{H}_2} = -0.75 + 0.059(1) = -0.691 \text{ V}$$

The effect of pH on the hydrogen overpotential of the iron electrode in an aqueous medium is shown in Fig. 3.2.

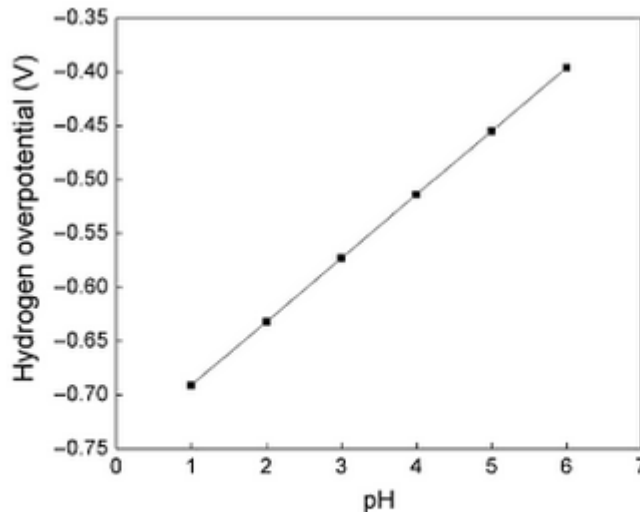

Fig. 3.2 The effect of pH on the hydrogen overpotential on iron electrode in aqueous medium.

23.

Determine the corrosion potential, the corrosion rate, and the protective current of zinc in 1 N hydrochloric acid. Assume that the entire zinc surface acts as a cathode, Tafel slopes are $b_a = 0.1$ V/decade and $b_c = -0.1$ V/decade, and the exchange current densities for zinc dissolution and for hydrogen evolution on zinc are 10^{-5} and 10^{-8} A/cm², respectively.

Additional information:

$$e_{\text{Zn}^{2+}/\text{Zn}}^{\circ} = -0.762 \text{ V vs. SHE} \quad e_{\text{H}^{+}/\text{H}_2}^{\circ} = 0.00 \text{ V vs. SHE}$$

$$i_{\text{Zn}}^{\circ} = 10^{-5} \text{ A/cm}^2 \quad i_{\text{H}_2}^{\circ} = 10^{-8} \text{ A/cm}^2$$

Solution:

Writing the Tafel equations for both the cathodic and anodic parts, we obtain:

$$E_{\text{corr}} - (-0.762) = 0.1 \log \left(\frac{I_{\text{corr}}}{10^{-5}} \right)$$

$$E_{\text{corr}} - 0.0 = -0.1 \log \left(\frac{I_{\text{corr}}}{10^{-8}} \right)$$

These two equations can be solved simultaneously for E_{corr} and I_{corr} . Adding both equations, we obtain:

$$2E_{\text{corr}} + 0.762 = 0.1 \log \left(\frac{I_{\text{corr}} 10^{-8}}{10^{-5} I_{\text{corr}}} \right)$$

$$E_{\text{corr}} = -0.531 \text{ V vs. SHE}$$

Substituting in the value of E_{corr} in one of the Tafel equations, one obtains:

$$I_{\text{corr}} = 2.04 \times 10^{-3} \text{ A/cm}^2$$

Because the protective potential is equal to the equilibrium potential or $E_{\text{prot}} = e_{\text{eq, Zn}^{2+} | \text{Zn}} = -0.762 \text{ V vs. SHE}$, the overvoltage necessary to stop the corrosion is:

$$\eta_{\text{prot}} = E_{\text{prot}} - e_{\text{eq, H}^+ | \text{H}_2} = -0.762 - 0.0 = -0.762 \text{ V vs. SHE.}$$

The protective current at protective potential is calculated by using the Tafel equation:

$$-0.762 - 0.0 = -0.1 \log \left(\frac{i_{\text{prot}}}{10^{-8}} \right)$$

$$i_{\text{prot}} = 0.42 \text{ A/cm}^2$$

Reference books

1. R. Winston Revie, Herbert H. Uhlig, *CORROSION AND CORROSION CONTROL*, Forth Edition, John Wiley & Sons, Inc, USA, 2008.
2. Mars Fontana, *CORROSION ENGINEERING*, Third edition, MicGraw – Hill, Singapore, 1987.
3. Nathan, C.C., *Corrosion Inhibitors*, NACE (1973).
4. West, J.M., *Electrodeposition and Corrosion Processes*, V.N.R. Co. (1971).