

Lecture (11)Rectifier Circuits

A **rectifier** is an electrical device that converts alternating current (AC), which periodically reverses direction, to direct current (DC), which flows in only one direction. The process is known as **rectification**. Rectifiers have many uses, but are often found serving as components of DC power supplies and high-voltage direct current power transmission systems

Block diagram of a dc power supply

□ DC power supply

- Generate a dc voltage from ac power sources
- The ac input is a low-frequency large-signal voltage

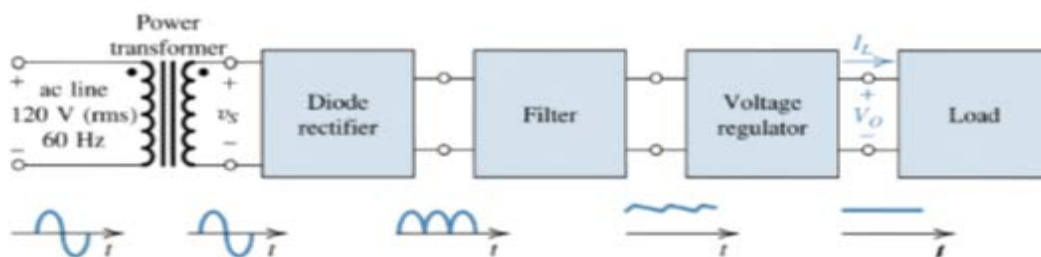

□ Power transformer

- Step the line voltage down to required value and provides electric isolation

□ Diode rectifier

- Converts the input sinusoidal to a unipolar output
- Can be divided to half-wave and full-wave rectifiers

□ Filter

- Reduces the magnitude variation for the rectifier output
- Equivalent to time-average operation of the input waveform

□ Voltage Regulator

- Further stabilizes the output to obtain a constant dc voltage
- Can be implemented by Zener diode circuits

Half-wave rectification

Simple Half-Wave Rectifier

- Only lets through positive voltages and rejects negative voltages
- This example assumes an ideal diode
- What would the waveform look like if not an ideal diode?

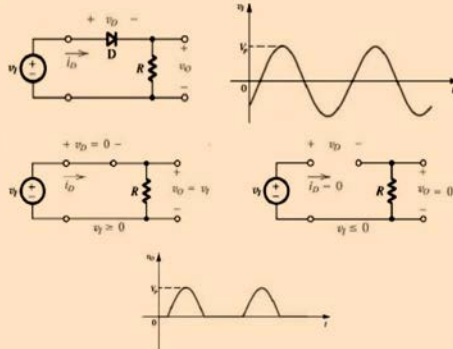

Circuit Operation

- During the positive alternation, the diode is forward biased and the full applied voltage is dropped across the load resistor.
- During the negative alternation, the diode is reverse biased and acts like an open circuit. No voltage is present across the load resistor.
- The output voltage is actually pulsating dc.
- An application for a half-wave rectifier is shown on the following slide.

Half-Wave Rectifier

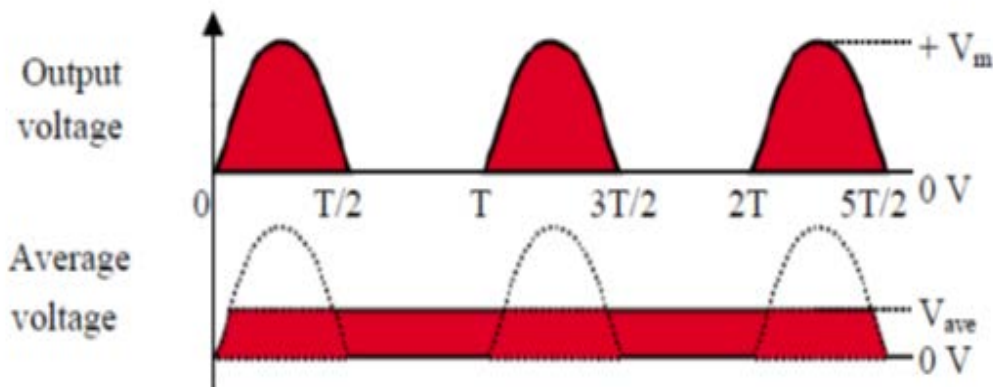
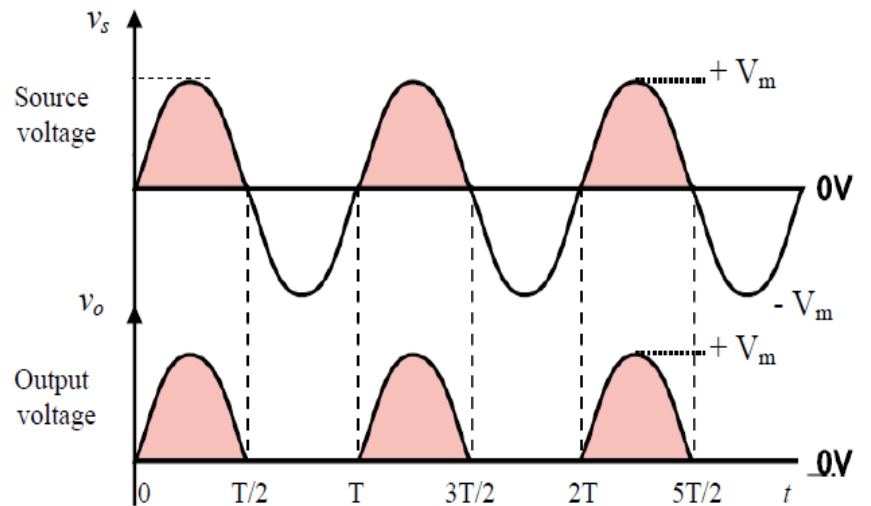
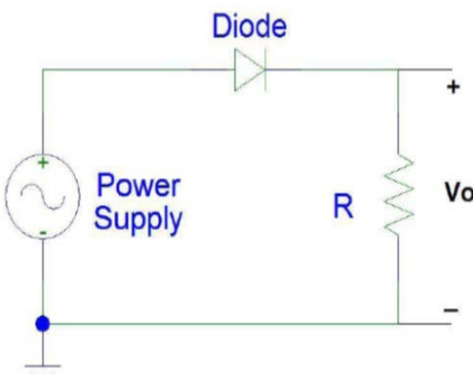

$$V_{ave} = \int_0^T v_o \cdot dt = \int_0^{T/2} V_m \sin(\omega t) \cdot dt + \int_{T/2}^T 0 \cdot dt$$

$$= \frac{2V_m}{\omega T} \left[\cos 0 - \cos \frac{\omega T}{2} \right] = \frac{2V_m}{2\pi} [\cos 0 - \cos \pi]$$

Or, $V_{ave} = \frac{V_m}{\pi}$

The no-load output DC voltage of an ideal half wave rectifier is:

$$V_{rms} = \frac{V_{peak}}{2}$$

$$V_{dc} = \frac{V_{peak}}{\pi}$$

Where:

- V_{dc}, V_{ave} - the dc or average output voltage,
- V_{peak} - the peak value of the phase input voltages = V_m ,
- V_{rms} - the root-mean-square value of output voltage.
- $\pi = \sim 3.14159$

Full-wave rectification

A full-wave rectifier converts the whole of the input waveform to one of constant polarity (positive or negative) at its output. Full-wave rectification converts both polarities of the input waveform to DC (direct current), and yields a higher mean output voltage. Two diodes and a center tapped transformer, or four diodes in a bridge configuration and any AC source (including a transformer without center tap), are needed. Single semiconductor diodes, double diodes with common cathode or common anode, and four-diode bridges, are manufactured as single components.

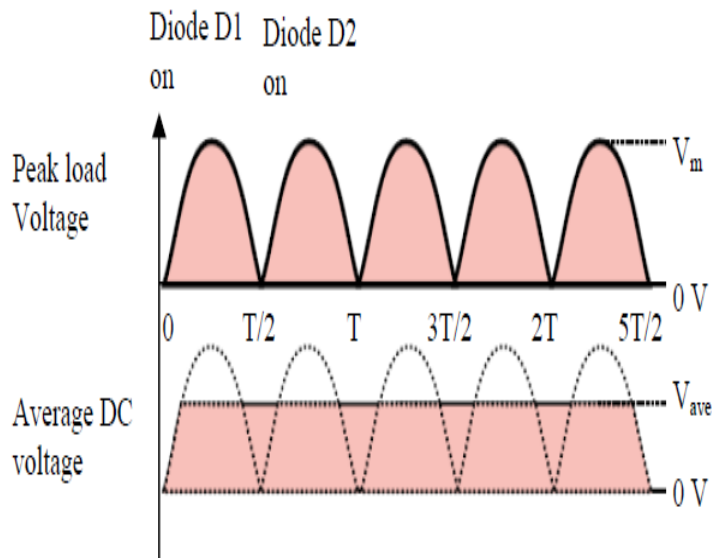
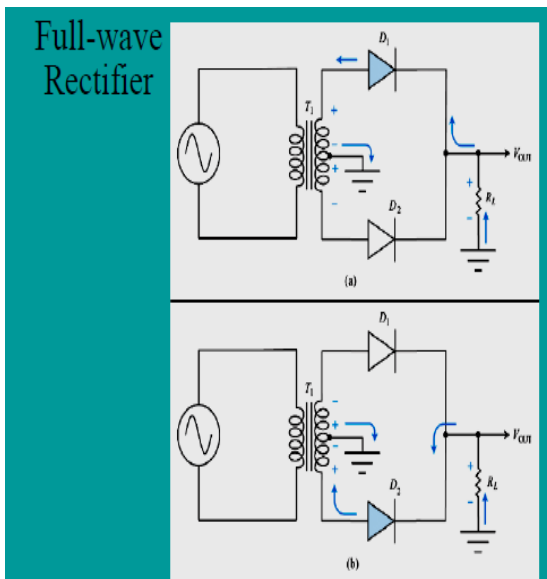

The average and root-mean-square no-load output voltages of an ideal single-phase full-wave rectifier are:

$$V_{dc} = V_{av} = \frac{2V_{peak}}{\pi}$$

$$V_{rms} = \frac{V_{peak}}{\sqrt{2}}$$

The Diode Voltage :

The d.c voltage is clearly given as:

$$V_{d.c} = I_{d.c} R_L = I_m R_L / \pi$$

d.c voltmeter reads the average value of the voltage across it:

$$V_{d.c} = 1/2\pi \int I_m R_f \sin \alpha \, d\alpha + \int V_m \sin \alpha \, d\alpha$$

$$= 1/2\pi (I_m R_f - V_m) = 1/\pi \{I_m R_f - R_f + R_L\}$$

$$V_{d.c} = -I_m R_L / \pi$$

The a.c current (a root-mean-square) ammeter is:

$$I_{r.m.s} = (1/2\pi \int i^2 \, d\alpha)^{1/2}$$

$$I_{r.m.s} = (1/2\pi \int I_m \sin^2 \alpha \, d\alpha)^{1/2}$$

$$I_{r.m.s} = I_m / \sqrt{2} \quad \& \quad V_{r.m.s} = V_m / \sqrt{2}$$

$$\text{ripple factor } (r) = (I_{r.m.s} / I_{d.c})$$

Rectifier efficiency:-

$$\eta = P_{d.c} / P_{a.c} * 100\%$$

CLAMPING CIRCUIT

A clamping circuit (also known as a clamper) is a special type of circuit that is used to limit or *clamp* the output voltage to a specified range. will bind the upper or lower extreme of a waveform to a fixed DC voltage level. These circuits are also known as DC voltage restorers. Clampers can be constructed in both positive and negative polarities. When unbiased, clamping circuits will fix the voltage lower limit (or upper limit, in the case of negative clampers) to 0 Volts. These circuits clamp a peak of a waveform to a specific DC level compared with a capacitively coupled signal which swings about its average DC level.

i.e clampers are used to change the D.C. level of a signal to a desired value Being different from clippers, clamping circuits uses a capacitor and a diode connection. When diode is in its on state, the output voltage equals to diode drop voltage (ideally zero) plus the voltage source, if any. Now let us examine the clamping process for the circuit in **below Figure**

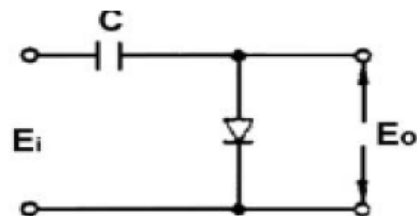
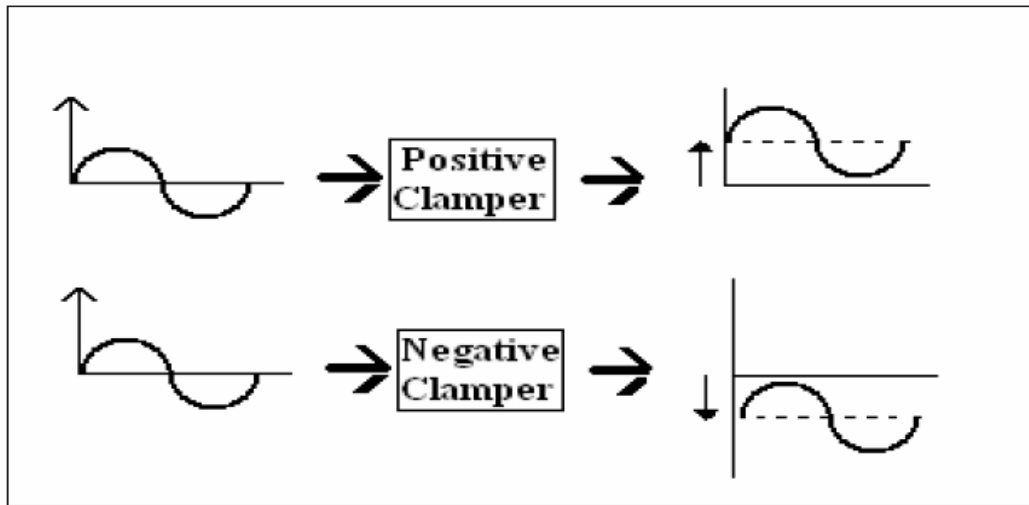

CLIPPING CIRCUIT

Clipping Circuits are used to eliminate amplitude noise or voltage spikes, voltage regulation or to produce new waveforms from an existing signal such as squaring off the peaks of a sinusoidal waveform to obtain a rectangular waveform. In other words Clipping circuit is a wave-shaping circuit, and is used to either remove or clip a portion of the applied wave in order to control the shape of the output waveform. One of the most basic clipping circuit is the half-wave rectifier. A half-wave rectifier clips either the negative half cycle or the positive half cycle of an alternating waveform, and allows to pass only one half cycle. Such a circuit has great applications in radars, digital computers and other electronic systems for removing unwanted portions of the input signal voltages above or below a specified level. Another application is in radio-receivers for communication circuits where noise pulses that rise well above the signal amplitude are clipped down to the desired level.

Positive Diode Clipping Circuits

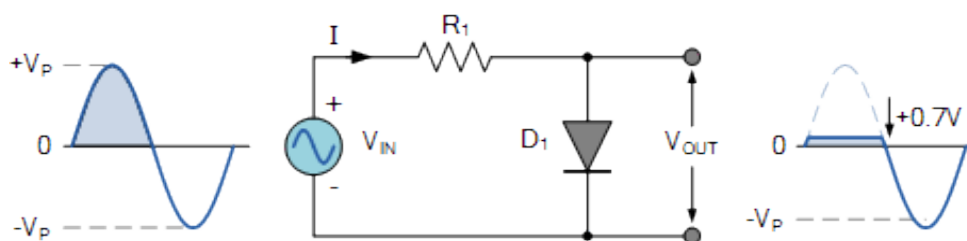

In this diode clipping circuit, the diode is forward biased (cathode more positive than anode) during the positive half cycle of the sinusoidal input waveform. For the diode to become forward biased, it must have the input voltage magnitude greater than +0.7 volts (0.3 volts for a germanium diode).

When this happens the diode begins to conduct and holds the voltage across itself constant at 0.7V until the sinusoidal waveform falls below this value. Thus the output voltage which is taken across the diode can never exceed 0.7 volts during the positive half cycle.

During the negative half cycle, the diode is reverse biased (anode more positive than cathode) blocking current flow through itself and as a result has no effect on the negative half of the sinusoidal voltage which passes to the load unaltered. Then the diode limits the positive half of the input waveform and is known as a positive clipper circuit.

Negative Diode Clipping Circuits

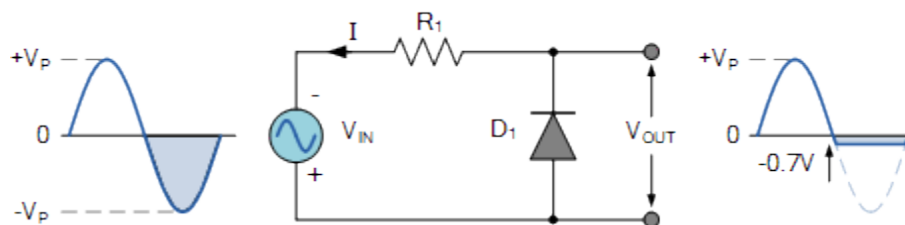

Here the reverse is true. The diode is forward biased during the negative half cycle of the sinusoidal waveform and limits or clips it to -0.7 volts while allowing the positive half cycle to pass unaltered when reverse biased. As the diode limits the negative half cycle of the input voltage it is therefore called a negative clipper circuit.

Clipping of Both Half Cycles

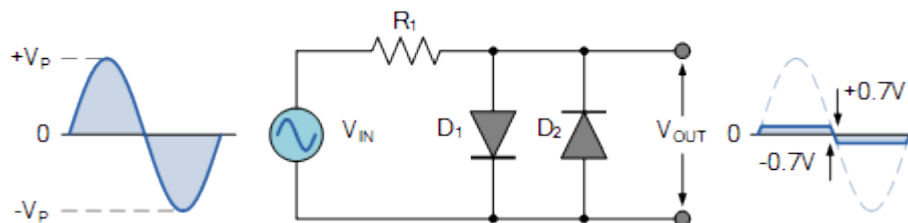

If we connected two diodes in inverse parallel as shown, then both the positive and negative half cycles would be clipped as diode D_1 clips the positive half cycle of the sinusoidal input waveform while diode D_2 clips the negative half cycle. Then diode clipping circuits can be used to clip the positive half cycle, the negative half cycle or both.

The advantage of biased diode clipping circuits is that it prevents the output signal from exceeding preset voltage limits for both half cycles of the input waveform, which could be an input from a noisy sensor or the positive and negative supply rails of a power supply.

Zener Diode Clipping

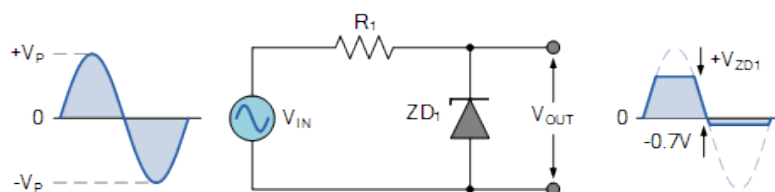

The Zener diode is acting like a biased diode clipping circuit with the bias voltage being equal to the zener breakdown voltage. In this circuit during the positive half of the waveform the zener diode is reverse biased so the waveform is clipped at the zener voltage, V_{ZD1} . During the negative half cycle the zener acts like a normal diode with its usual 0.7V junction value. We can develop this idea further by using the zener diodes reverse-voltage characteristics to clip both halves of a waveform using series connected back-to-back zener diodes as shown.

Full-wave Zener Diode Clipping

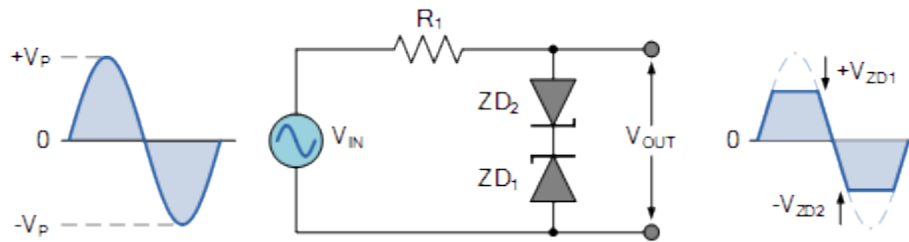

The output waveform from full wave zener diode clipping circuits resembles that of the previous voltage biased diode clipping circuit. The output waveform will be clipped at the zener voltage plus the 0.7V forward volt drop of the other. So for example, the positive half cycle will be clipped at the sum of zener diode, ZD_1 plus 0.7V from ZD_2 and vice versa for the negative half cycle.